

TECHNICAL MANUAL

**UNIT AND DIRECT SUPPORT
REPAIR PARTS AND SPECIAL TOOLS LISTS**

FOR

SHELTER, ELECTRICAL EQUIPMENT

S-250/G UNSHIELDED

(NSN 5411-00-999-4935)

S-250/G SHIELDED

(NSN 5411-00-489-6076)

Approved for public release; distribution is unlimited.

***This manual supersedes S-250/G data of TM 11-5410-214-12P and TM 11-5410-214-34P,
both dated 27 December 1978.**

HEADQUARTERS, DEPARTMENT OF THE ARMY

24 JUNE 1991

CHANGE

NO. 1

HEADQUARTERS
DEPARTMENT OF THE ARMY
WASHINGTON, D.C., 30 SEPTEMBER 1992

Unit and Direct Support Repair Parts and Special Tools Lists

SHELTER, ELECTRICAL EQUIPMENT
S-250/G UNSHIELDED (NSN 5411-00-999-4935)
S-250/G SHIELDED (NSN 5411-00-489-6076)

Approved for public release; distribution is unlimited

TM 10-5411-205-23P, 24 June 1991, is changed as follows:

1. Remove and insert pages as indicated below. New or changed text material is indicated by a vertical bar in the margin. An illustration change is indicated by a miniature pointing hand.

Remove pages

i/(ii blank)
fig 2
3-1 and 3-2
1-3 and 1-4
1-7 through 1-10

Insert pages

i/(ii blank)
fig 2
3-1 and 3-2
1-3 and 1-4
1-7 through 1-10

2. Retain this sheet in front of manual for reference purposes.

By Order of the Secretary of the Army:

OFFICIAL:

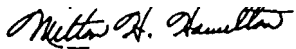

MILTON H. HAMILTON
*Administrative Assistant to the
Secretary of the Army*

GORDON R. SULLIVAN
*General, United States Army
Chief of Staff*

DISTRIBUTION:

To be distributed in accordance with DA Form 12-25-E, block 5715,
Unit and Direct Support Maintenance requirements for TM 10-5411-205-23P.

**UNIT AND DIRECT SUPPORT
REPAIR PARTS AND SPECIAL TOOLS LISTS
FOR
SHELTER, ELECTRICAL EQUIPMENT
S-250/G UNSHIELDED (NSN 5411-00-999-4935)
S-250/G SHIELDED (NSN 5411-00-489-6076)**

Current as of 16 May 1991

REPORTING ERRORS AND RECOMMENDING IMPROVEMENTS

You can help improve this manual. If you find any mistakes or if you know of a way to improve the procedures, please let us know. Mail your letter, DA Form 2028 (Recommended Changes to Publications and Blank Forms) or DA Form 2028-2 located in the back of this manual directly to: Commander, U.S. Army Troop Support Command, ATTN: AMSTR-MMTS, 4300 Goodfellow Boulevard, St. Louis, MO 63120-1798. A reply will be furnished directly to you.

Approved for public release; distribution is unlimited

		Page	ILLUS/ Figure
SECTION I.	INTRODUCTION	1	
SECTION II.	REPAIR PARTS LIST	1-1	
GROUP 00	Shelter, Electrical Equipment S-250/G	1-1	1
01	Outer DooR Assembly	2-1	2
02	Inner Door Assembly	3-1	3
03	Door Stay Assembly	4-1	4
04	Skid Assembly	5-1	5
05	Towing Bracket Assembly	6-1	6
06	Lifting Bracket Assembly	7-1	7
SECTION III.	Special Tools List (Not Applicable)		
SECTION IV.	Cross Reference Indexes	I-1	
	National Stock Number Index	I-1	
	Part Number Index	I-3	
	Figure and Item Number index	I-8	

*This manual supersedes TM 11-5410-214-12P and TM 11-5410-214-34P, both dated 27 December 1978. ■

**UNIT AND DIRECT SUPPORT
REPAIR PARTS AND SPECIAL TOOLS LIST**

SECTION I. INTRODUCTION

1. **SCOPE.** This RPSTL lists and authorizes spares and repair parts; special tools; special test, measurement, and diagnostic equipment (TMDE); and other special support equipment required for performance of unit, direct support, and general support maintenance of the S-250/G Unshielded and S-250/G Shielded shelters. It authorizes the requisitioning, issue, and disposition of spares, repair parts and special tools as indicated by the source, maintenance and recoverability (SMR) codes.

2. **GENERAL.** In addition to this section, Introduction, this Repair Parts and Special Tools List is divided into the following sections:

a. Section II. Repair Parts List. A list of spares and repair parts authorized by this RPSTL for use in the performance of maintenance. The list also includes parts which must be removed for replacement of the authorized parts. Parts lists are composed of functional groups in ascending alphanumeric sequence, with the parts in each group listed in ascending figure and item number sequence. Bulk materials are listed in item name sequence. Repair parts kits are listed separately in their own functional group within Section II. Repair parts for repairable special tools are also listed in this section. Items listed are shown on the associated illustration(s)/figure(s).

b. Section III. Special Tools List. A list of special tools, special TMDE, and other special support equipment authorized by this RPSTL (as indicated by Basis of Issue (BOI) information in DESCRIPTION AND USABLE ON CODE column) for the performance of maintenance.

c. Section IV. Cross-references Indexes. A list, in National Item Identification Number (NIIN) sequence, of all National stock numbered items appearing in the listing, followed by a list in alphanumeric sequence of all part numbers appearing in the listings. National stock numbers and part numbers are cross referenced to each illustration figure and item number appearance. The figure and item number index lists figure and item number in alphanumeric sequence and cross references NSN, CAGEC and part number.

3. **EXPLANATION OF COLUMNS (SECTIONS II AND III).**

a. ITEM NO. (Column (1)). Indicates the number used to identify items called out in the illustration.

b. SMR Code (Column (2)). The Source, Maintenance, and Recoverability (SMR) code is a 5–position code containing supply/requisitioning information, maintenance category authorization criteria, and disposition instruction, as shown in the following breakout:

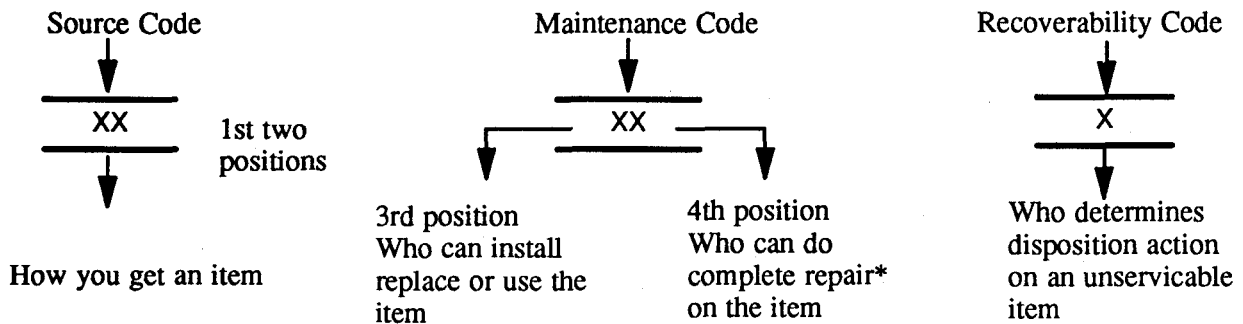

*Complete Repair: Maintenance capacity, capability, and authority to perform all corrective maintenance tasks of the "Repair" function in a use/user environment in order to restore serviceability to a failed item.

(1) **Source Code.** The source code tells you how to get an item needed for maintenance, repair, or overhaul of an end item/equipment. Explanations of source codes follows:

Code	Explanation
PA PB PC** PD PE PF PG KD KF KB	<p>Stocked items; use the applicable NSN to request/requisition items with these source codes. They are authorized to the category indicated by the code entered in the 3rd position of the SMR code.</p> <p>**NOTE: Items coded PC are subject to deterioration.</p> <p>Items with these codes are not to be requested/requisitioned individually. They are part of a kit which is authorized to the maintenance category indicated in the 3rd position of the SMR code. The complete kit must be requisitioned and applied.</p>
MO — (Made at org AVUM Level) MF — (Made at DS/AVUM Level) MH — (Made at GS Level) ML — (Made at Specialized Repair Activity (SRA)) MD — (Made at Depot)	<p>Items with these codes are not to be requested/requisitioned individually. They must be made from bulk material which is identified by the part number in the DESCRIPTION and USABLE ON CODE (UOC) column and listed in the Bulk Material group of the repair parts list in this RPSTL. If the item is authorized to you by the 3rd position code of the SMR code, but the source code indicates it is made at a higher level, order the item from the higher level of maintenance.</p>
AO — (Assembled by org/AVUM Level) A F — (Assembled by DS/AVIM Level) AH — (Assembled by GS Category) AL — (Assembled by SRA) AD — (Assembled by Depot)	<p>Items with these codes are not to be requested/requisitioned individually. The parts that make up the assembled item must be requisitioned or fabricated and assembled at the level of maintenance indicated by the source code. If the 3rd position code of the SMR code authorizes you to replace the item, but the source code indicates the items are assembled at a higher level, order the item from the higher level of maintenance.</p>
XA —	Do not requisition “XA” -coded item. Order its next higher assembly. (Also, refer to the NOTE below.)
XB —	If an “XB” item is not available from salvage, order it using the CAGEC and part number given.
XC —	Installation drawing, diagram, instruction sheet, field service drawing, that is identified by Reciprocating Compressor manufacturer’s part number.
XD —	Item is not stocked. Order an “XD” -coded item through normal supply channels using the CAGEC and part number given if no NSN is available.

NOTE

Cannibalization or controlled exchange, when authorized, may be used as a source of supply for items with the above source codes, except for those source coded "XA" or those aircraft support items restricted by requirements of AR 750-1.

(2) Maintenance Code. Maintenance codes tells you the level(s) of maintenance authorized to USE and REPAIR support items. The maintenance codes are entered in the third and fourth positions of the SMR code as follows:

(a) The maintenance code entered in the third position tells you the lowest maintenance level authorized to remove, replace, and use an item. The maintenance code entered in the third position will indicate authorization to one of the following levels of maintenance.

Code	Application/Explanation
C —	Crew or operator maintenance done within organizational or aviation unit maintenance.
O —	Organizational or aviation unit category can remove, replace, and use the item.
F —	Direct support or aviation intermediate level can remove, replace, and use the item.
H —	General support level can remove, replace, and use the item.
L —	Specialized repair activity can remove, replace, and use the item.
D —	Depot level can remove, replace, and use the item.

(b) The maintenance code entered in the fourth position tells whether or not the item is to be repaired and identifies the lowest maintenance level with the capability to do complete repair (i.e., perform all authorized repair functions.) NOTE: Some limited repair may be done on the item at a lower level of maintenance, if authorized by the Maintenance Allocation Chart (MAC) and SMR codes. This position will contain one of the following maintenance codes.

Code	Application/Explanation
O —	Organizational or (aviation unit) is the lowest level that can do complete repair of the item.
F —	Direct support or aviation intermediate is the lowest level that can do complete repair of the item.
H —	General Support is the lowest level that can do complete repair of the item.
L —	Specialized repair activity is the lowest level that can do complete repair of the item.
D —	Depot is the lowest level that can do complete repair of the item.
Z —	Nonreparable. No repair is authorized.
B —	No repair is authorized. (No parts or special tools are authorized for the maintenance of a "B" coded item). However, the item may be reconditioned by adjusting, lubricating, etc., at the user level.

(3) Recoverability Code. Recoverability codes are assigned to items to indicate the disposition action on unserviceable items. The recoverability code is entered in the fifth position of the SMR Code as follows:

TM 10-5411-205-23P

Recoverability

Codes	Application/Explanation
Z —	Nonreparable item. When unserviceable, condemn and dispose of the item at the level of maintenance shown in third position of SMR Code.
O —	Reparable item. When not economically reparable, condemn and dispose of the item at organizational or aviation unit level
F —	Reparable item. When uneconomically reparable, condemn and dispose of the item at the direct support or aviation intermediate level
H —	Reparable item. When uneconomically reparable, condemn and dispose of the item at the general support level.
D —	Reparable item. When beyond lower level repair capability, return to depot. Condemnation and disposal of item not authorized below depot level.
L —	Reparable item. Condemnation and disposal not authorized below specialized repair activity (SRA).
A —	Item requires special handling or condemnation procedures because of specific reasons (e.g., precious metal content, high dollar value, critical material, or hazardous material). Refer to appropriate manuals/directives for specific instructions.

c. CAGEC (Column (3)). The Commercial and Government Entity Code (CAGEC) is a 5-digit numeric code which is used to identify the manufacturer, distributor, or Government agency, etc., that supplies the item.

d. PART NUMBER (Column (4)). Indicates the primary number used by the manufacturer, (individual, company, firm, corporation, or Government activity), which controls the design and characteristics of the item by means of its engineering drawings, specifications standards, and inspection requirements to identify an item or range of items.

NOTE

When you use an NSN to requisition an item, the item you receive may have a different part number from the part ordered.

e. DESCRIPTION AND USABLE ON CODE (UOC) (Column (5)). This column includes the following information:

- (1) The Federal item name and, when required, a minimum description to identify the item.
- (2) The physical security classification of the item is indicated by the parenthetical entry, e.g., PhySec Cl - Confidential, Phy Sec Cl (S) - Secret, Phy Sec Cl (T) – Top Secret.
- (3) Items that are included in kits and sets are listed below the name of the kit or set.
- (4) Spate/repair parts that make up an assembled item are listed immediately following the assembled item line entry.
- (5) Part numbers for bulk materials are referenced in this column in the line item entry for the item to be manufactured/fabricated.
- (6) When the item is not used with all serial numbers of the same model, the effective serial numbers are shown on the last line(s) of the description (before UOC).

(7) The usable on code, when applicable (see paragraph 5, Special Information).

(8) In the Special Tools List section, the basis of issue (BOI) appears as the last line(s) in the entry for each special tool, special TMDE, and other special support equipment. When density of equipments supported exceeds density spread indicated in the basis of issue, the total authorization is increased proportionately.

(9) The statement "END OF FIGURE" appears just below the last item description in Column 5 for a given figure in both Section II and Section III.

(10) The indenture, shown as dots appearing before the repair part, indicates that the item is a repair part of the next higher assembly.

f. QTY (Column (6)). The QTY (quantity per figure column) indicates the quantity of the item used in the breakout shown on the illustration figure, which is prepared for a functional group, subfunctional group, or an assembly. A "V" appearing in this column in lieu of a quantity indicates that the quantity is variable and may vary from application to application.

4. EXPLANATION OF COLUMNS (SECTION IV).

a. NATIONAL STOCK NUMBER (NSN) INDEX.

(1) **STOCK NUMBER column.** This column lists the NSN by National item identification number (NIIN) sequence. The NIIN consists of the last nine digits of the NSN, i.e.

NSN

5305-01-574-1467
NIIN

When using this column to locate an item, ignore the first 4 digits of the NSN. However, the complete NSN should be used when ordering items by stock number.

(2) **FIG. column.** This column lists the number of the figure where the item is identified/located. The figures are in numerical order in Section II and Section III.

(3) **ITEM column.** The item number identifies the item associated with the figure listed in the adjacent FIG. column. This item is also identified by the NSN listed on the same line.

b. PART NUMBER INDEX. Part numbers in this index are listed by part number in ascending alphanumeric sequence (ie., vertical arrangement of letter and number combination which places the first letter or digit of each group in order A through Z, followed by the numbers 0 through 9 and each following letter or digit in like order).

(1) **CAGEC column.** The Commercial and Government Entity Code (CAGEC) is a 5-digit numeric code used to identify the manufacturer, distributor, or Government agency, etc., that supplies the item.

(2) **PART NUMBER column.** Indicates the primary number used by the manufacturer (individual, firm, corporation, or Government activity), which controls the design and characteristics of the item by means of its engineering drawings, specifications standards, and inspection requirements to identify an item or range of items.

(3) **STOCK NUMBER column.** This column lists the NSN for the associated part number and manufacturer identified in the PART NUMBER and CAGEC columns to the left.

(4) **FIG. column.** This column lists the number of the figure where the item is identified/located in Sections II and III.

(5) **ITEM column.** The item number is that number assigned to the item as it appear in the figure referenced in adjacent figure number column.

c. FIGURE AND ITEM NUMBER INDEX.

(1) **FIG. column.** This column lists the number of the figure where the item is identified/located in Section II and III.

(2) **ITEM column.** The item number is that number assigned to the item as it appears in the figure referenced in the adjacent figure number column.

(3) **STOCK NUMBER column.** This column lists the NSN for the item.

(4) **CAGEC column.** The Commercial and Government Entity Code (CAGEC) is a 5-digit numeric code used to identify the manufacturer, distributor, or Government agency, etc., that supplies the item.

(5) **PART NUMBER column.** Indicates the primary number used by the manufacturer (individual, firm, corporation, or Government activity), which controls the design and characteristics of the item by means of its engineering drawings, specifications standards, and inspection requirements to identify an item or range of items.

5. SPECIAL INFORMATION.

a. USABLE ON CODE. The usable on code appears in the lower corner of the Description column heading. Usable on codes are shown as "UOC:....." in the Description Column (justified left) on the last line applicable item description nomenclature. Uncoded items are applicable to all models.

b. ASSOCIATED PUBLICATIONS. The publications listed below pertain to the S-250/G Unshielded and S-250/G Shielded shelters and its components.

Publication	Short Title
TM 10-5411-205-14 ¹³	Shelter, Electrical Equipment S-250/G Unshielded and S-250/G Shielded

6. HOW TO LOCATE REPAIR PARTS.

a. When National Stock Number or Part Number is NOT Known.

(1) **First.** Using the table of contents, determine the assembly group or subassembly group to which the item belongs. This is necessary since figures are prepared for assembly groups and subassembly groups, and listings are divided into the same groups.

(2) **Second.** Find the figure covering the assembly group or subassembly group to which the item belongs.

(3) **Third.** Identify the item on the figure and note the item number.

(4) Fourth. Refer to the Repair Parts List for the figure to find the part number for the item number noted on the figure.

(5) Fifth. Refer to the Part Number Index to find the NSN, if assigned.

b. When National Stock Number or Part Number IS Known.

(1) First. Using the Index of National Stock Numbers and Part Numbers, find the pertinent National Stock Number or Part Number. The NSN index is in National Item Identification Number (NIIN) sequence (see c-4a.(1)). The part numbers in the Part Number index are listed in ascending alphanumeric sequence (see paragraph c-4.b). Both indexes cross-reference you to the illustration figure and item number of the item you are looking for.

(2) Second. After finding the figure and item number, verify that the item is the one you are looking for, then locate the item number in the repair parts list for the figure.

7. ABBREVIATIONS. Abbreviations used in this manual are listed in MIL-STD-12.

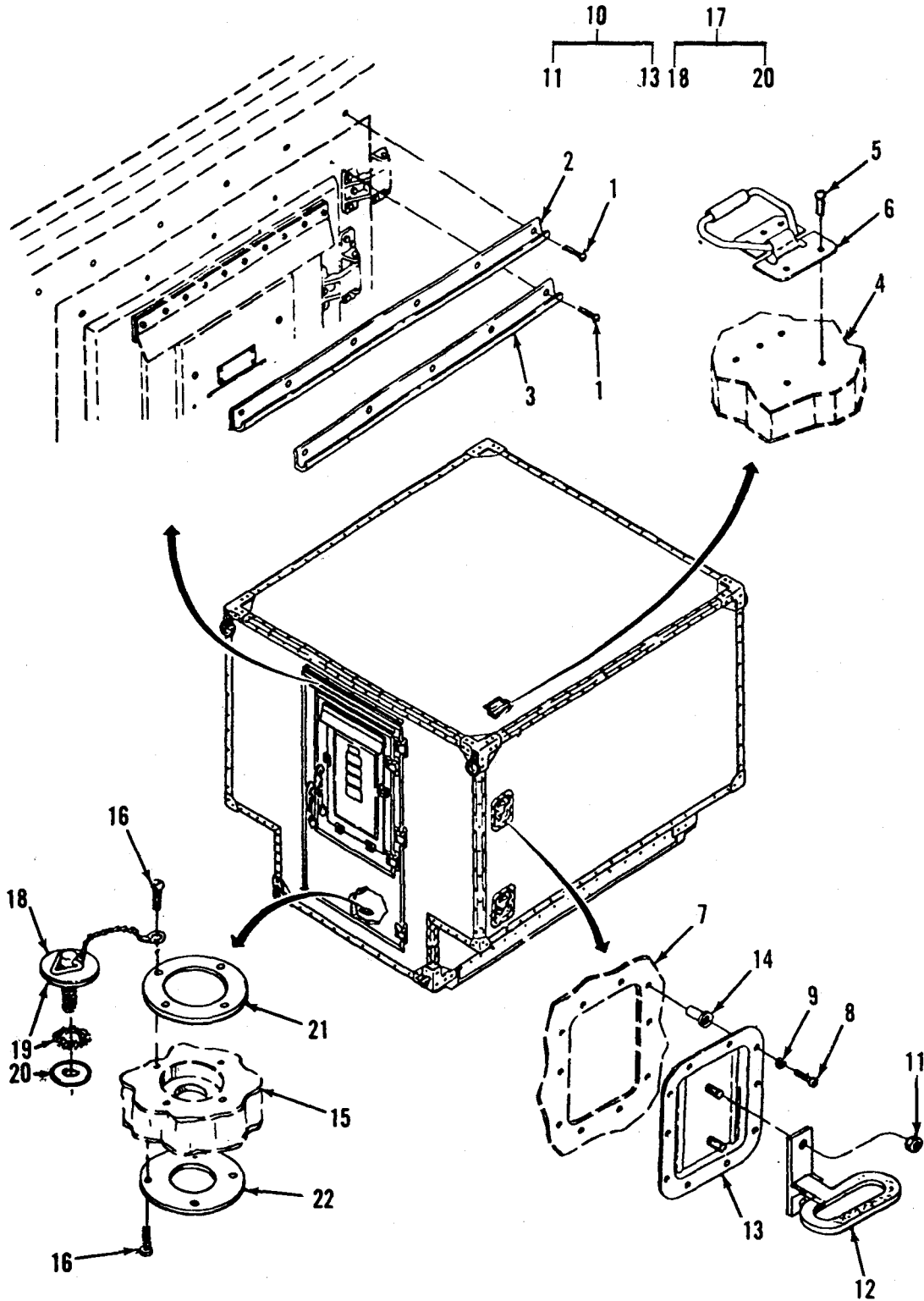

Figure 1. Shelter, Electrical Equipment S-250/G (Sheet 1 of 4)

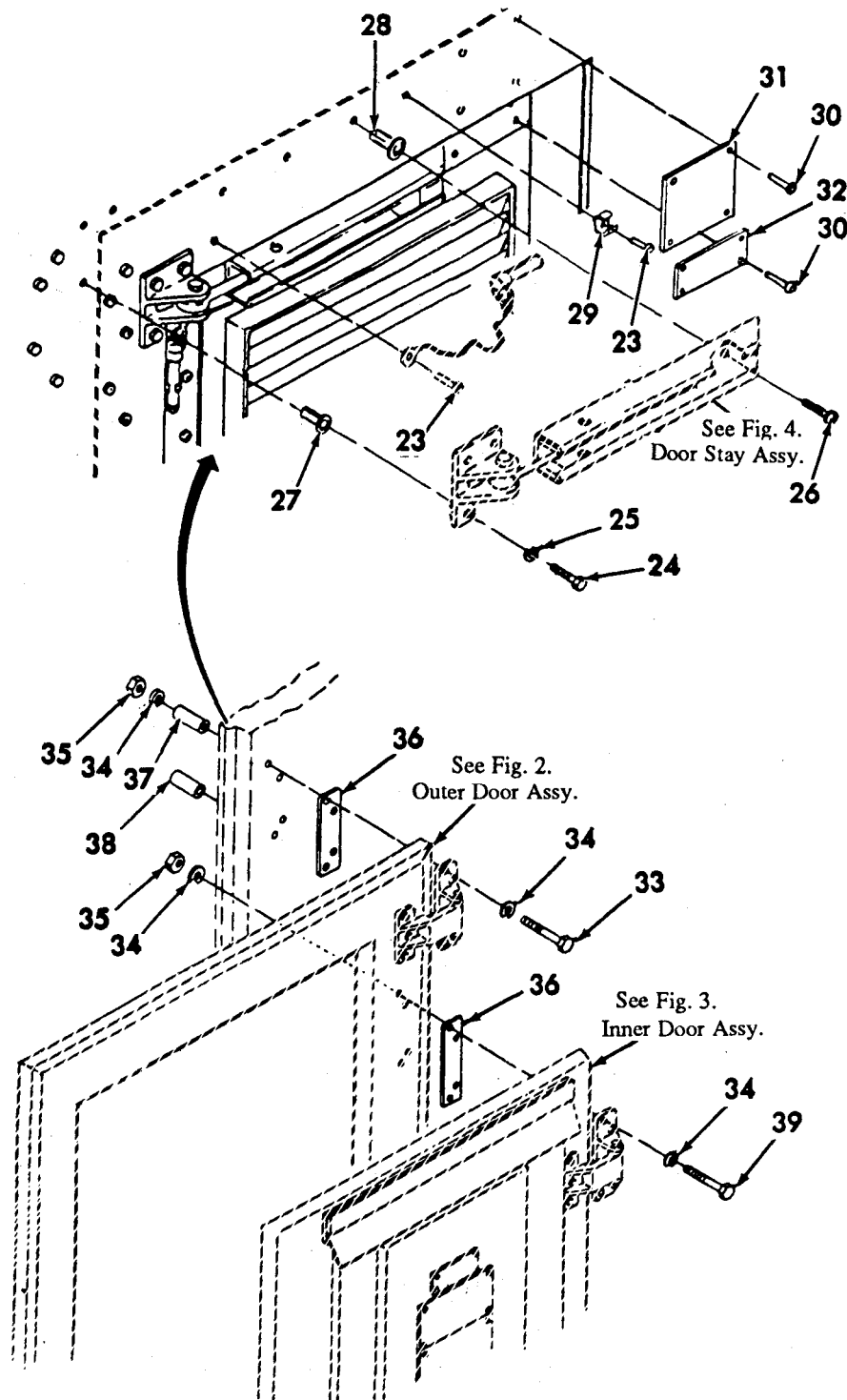

Figure 1. Shelter, Electrical Equipment S-250/G (Sheet 2 of 4)

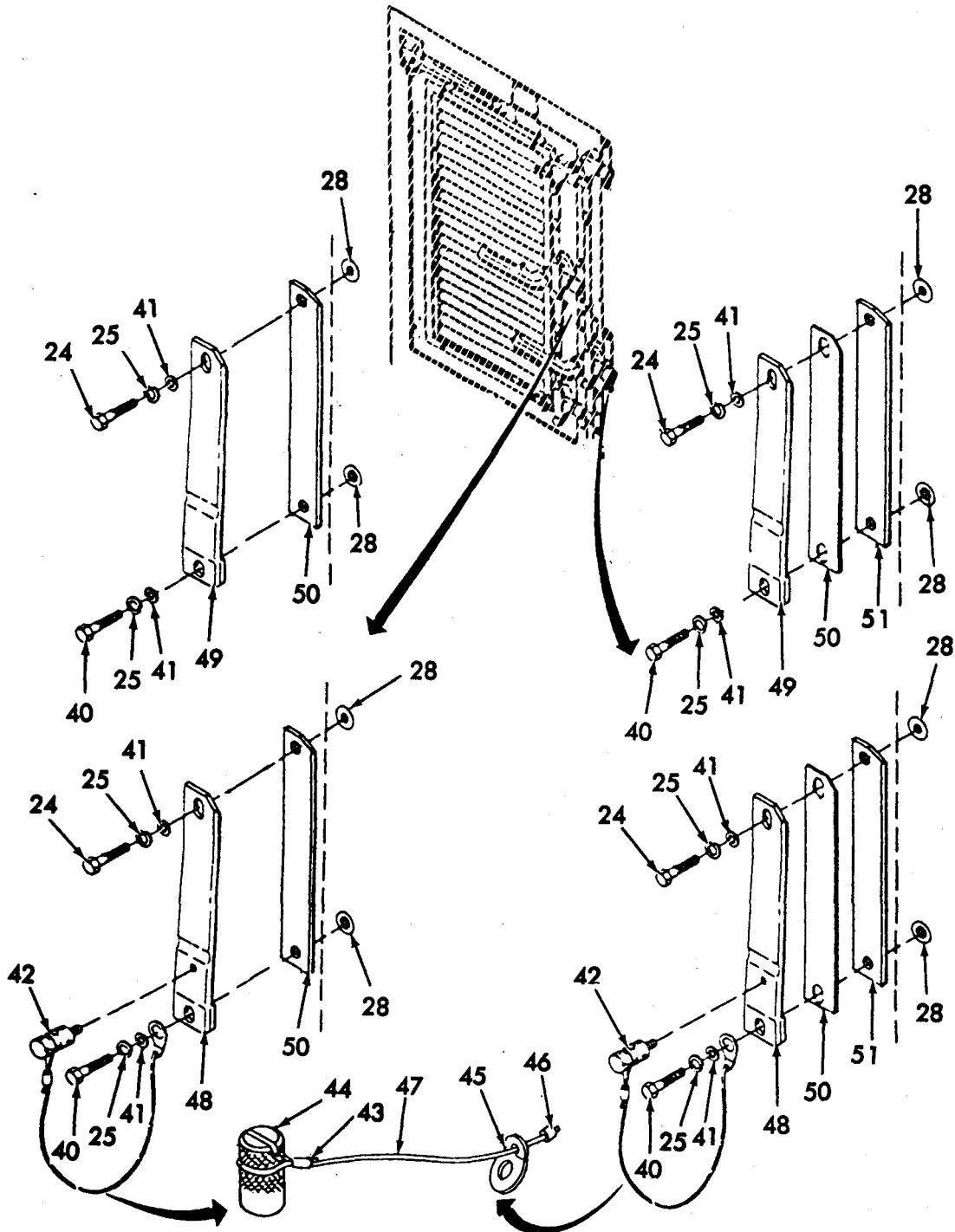

Figure 1. Shelter, Electrical Equipment S-250/G (Sheet 3 of 4)

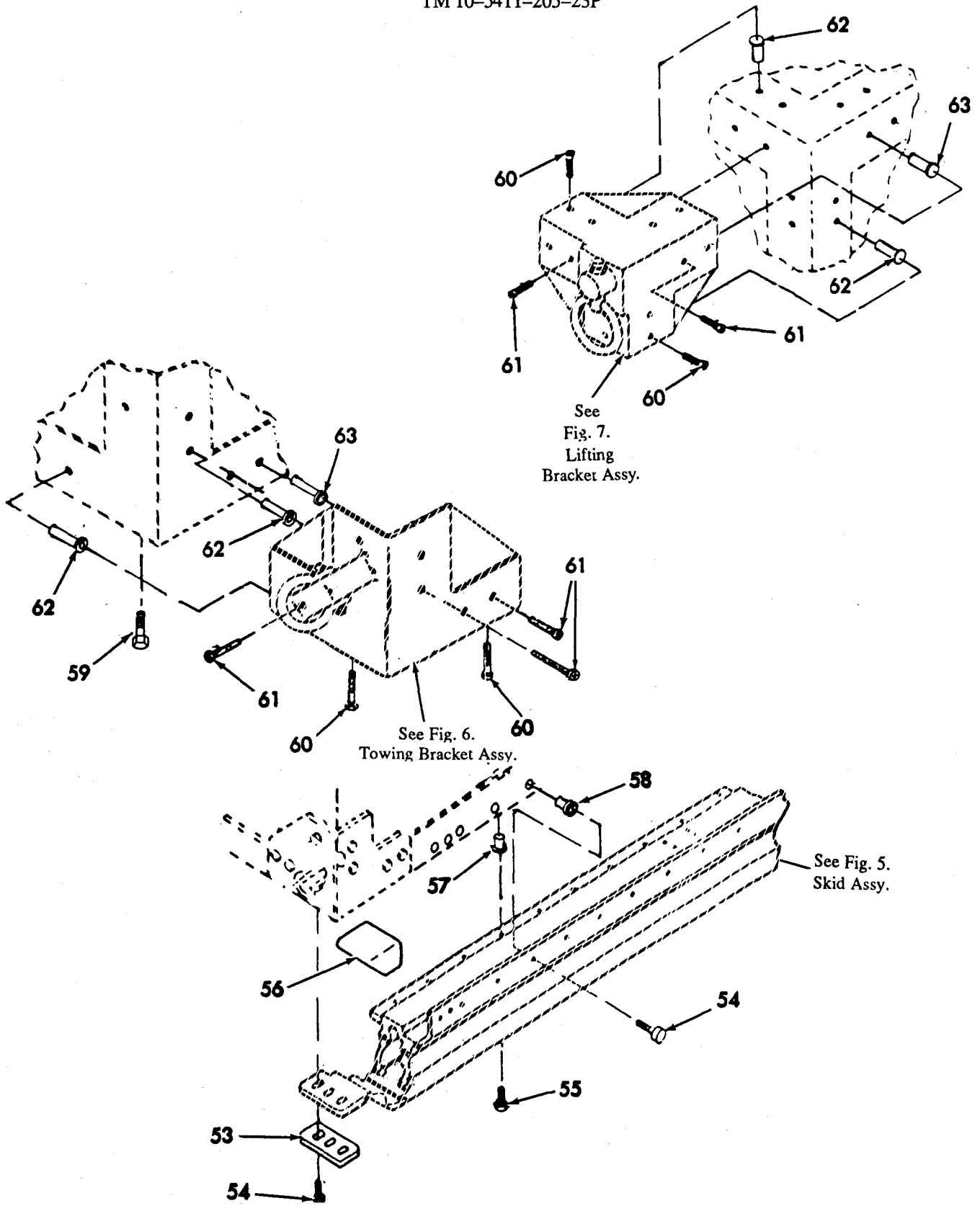

Figure 1. Shelter, Electrical Equipment S-250/G (Sheet 4 of 4)

SECTION II		TM10-5411-205-23P				
(1)	(2)	(3)	(4)	(5)		(6)
ITEM NO	SMR CODE	CAGEC	PART NUMBER	DESCRIPTION AND USABLE ON CODES (UOC)		QTY
				GROUP 00 SHELTER, ELECTRICAL EQUIP. S-250/G		
				FIG. 1 SHELTER, ELECTRICAL EQUIP. S-250/G		
1	PAOZZ	81352	AN504-8R12	SCREW		35
2	XBOZZ	81337	SM-C-650081-1	TROUGH		1
3	XBOZZ	81337	SM-C-650081-2	TROUGH		1
4	XBFZZ	81337	SM-D-650014	ROOF PANEL		1
5	PAOZZ	07707	AD64H	.RIVET, BLIND		5
6	PAOZZ	81337	SM-C-563619	.HANDLE, BAIL		1
7	XBFZZ	81337	SM-D-650015	CURBSIDE PANEL		1
8	PAOZZ	96906	MS35206-230	.SCREW, MACHINE		20
9	PAOZZ	96906	MS35338-44	.WASHER, LOCK		20
10	PAOOO	19220	AL1-575709	.PAN ASSEMBLY, RECESS		2
11	PAOZZ	19220	15949	..LOCKNUT		2
12	PAOZZ	19220	1-575709-50	..STEP, FOLDING		1
13	PAOZZ	19220	AL1-6040	..PAN, RECESSED STEP		1
14	XDOZZ	03481	S25B151	.NUT, PLAIN, BLIND RIV .332 X .089 - .151 GRIP		20
15	XBFZZ	81337	SM-D-650019	FLOOR PANEL		1
16	PAOZZ	81352	AN504C-1032R8	.SCREW		8
17	PAOOZ	59647	68505-3	.STOPPER, WASTE DRAIN		1
18	PAOZZ	59647	68505-2	..PLUG, DRAIN		1
19	PAOZZ	81337	SM-B-374181	..WASHER, EMI		1
20	PAOZZ	81337	SM-B-374182	..WASHER, FLAT		1
21	PAOZZ	81337	SM-B-650105	.SPACER, PLATE		1
22	XDOZZ	81337	SM-B-563518	.COVER		1
23	PAOZZ	07707	AD44H	RIVET, BLIND		4
24	PAOZZ	96906	MS35307-308	SCREW, CAP, HEXAGON H		12
25	PAOZZ	96906	MS35338-158	WASHER, LOCK		18
26	PAOZZ	96906	MS51953-80	NIPPLE, PIPE		6
27	PAOZZ	73957	25020-12	INSERT		5
28	PAOZZ	03481	S25B211	NUT, PLAIN, BLIND RIV		19
29	PAOZZ	96906	MS17160-108	CLIP, SPRING TENSION		2
30	PAOZZ	96906	MS51861-15C	.SCREW, TAPPING, THREA		8
31	XBOZZ	81337	SM-B-340031	PLATE, AIRBORNE		1
32	XBOZZ	81337	SM-B-650097	PLATE, INSTRUCTION		1
33	PAOZZ	96906	MS35307-315	SCREW, CAP, HEXAGON H		12
34	PAOZZ	96906	MS35333-74	WASHER, LOCK		40
35	PAOZZ	96906	MS16228-4C	NUT, SELF-LOCKING, HE		20
36	PAOZZ	80063	SM-B-650118	SPACER, PLATE		V
37	PAOZZ	80063	SMB650102-1	SPACER, SLEEVE		7
38	PAOZZ	80063	SMB650102-2	SPACER, SLEEVE		5
39	PAOZZ	96906	MS35307-318	SCREW, CAP, HEXAGON H		8
40	PAOZZ	96906	MS35307-310	SCREW, CAP, HEXAGON H		4
41	PAOZZ	96906	MS27183-10	WASHER, FLAT		8
42	PAOOZ	81337	SC-B-781197	LATCH LOCK ASSEMBLY		2
43	XAOZZ	96906	MS51844-62	.SWAGING SLEEVE, WIRE		1
44	XAOZZ	81337	SC-B-781198	.PIN		1
45	XAOZZ	81337	SC-B-781199	.TAB		1

SECTION II (1)	SMR (2)	CAGEC (3)	TM10-5411-205-23P PART (4)	DESCRIPTION AND USABLE ON CODES (UOC)	(6)
ITEM NO	CODE		NUMBER		QTY
46	XAOZZ	76691	NICOPRESS 071-1-Q	.STOP SLEEVE	1
47	XAOZZ	81349	MIL-C-5424	.ROPE,WIRE	V
48	XBOZZ	81337	SC-B-781203	KEEPER,TAPPED	2
49	XBOZZ	81337	SM-C-435904	KEEPER	2
50	XBOZZ	81337	SM-B-650122	SHIM,KEEPER	4
51	XBOZZ	81337	SM-B-435899-2	SHIM,LAMINATED	V
52	PAOZZ	81337	SM-B-563545	BOLT,SHOULDER	12
53	XBOZZ	81337	SM-B-563546	PLATE	4
54	PAOZZ	96906	MS51957-81	SCREW, MACHINE	28
55	PAOZZ	96906	MS51957-83	SCREW,MACHINE	48
56	XDOZZ	81337	SM-D-563543	BLOCK,RUBBER	4
57	PAOZZ	96906	MS27131-51	NUT,PLAIN,BLIND RIV	28
58	PAOZZ	03481	S25B451	NUT,BLIND RIVET	48
59	PAOZZ	96906	MS35307-309	SCREW,CAP,HEXAGON H	12
60	XAOZZ	96906	MS24667-31	SCREW	4
61	XAOZZ	96906	MS24667-42	SCREW	44
62	XAOZZ	03481	S25B320	NUT,BLIND RIVET	52
63	PAOZZ	03481	S31B425	NUT,BLIND RIVET	44

END OF FIGURE

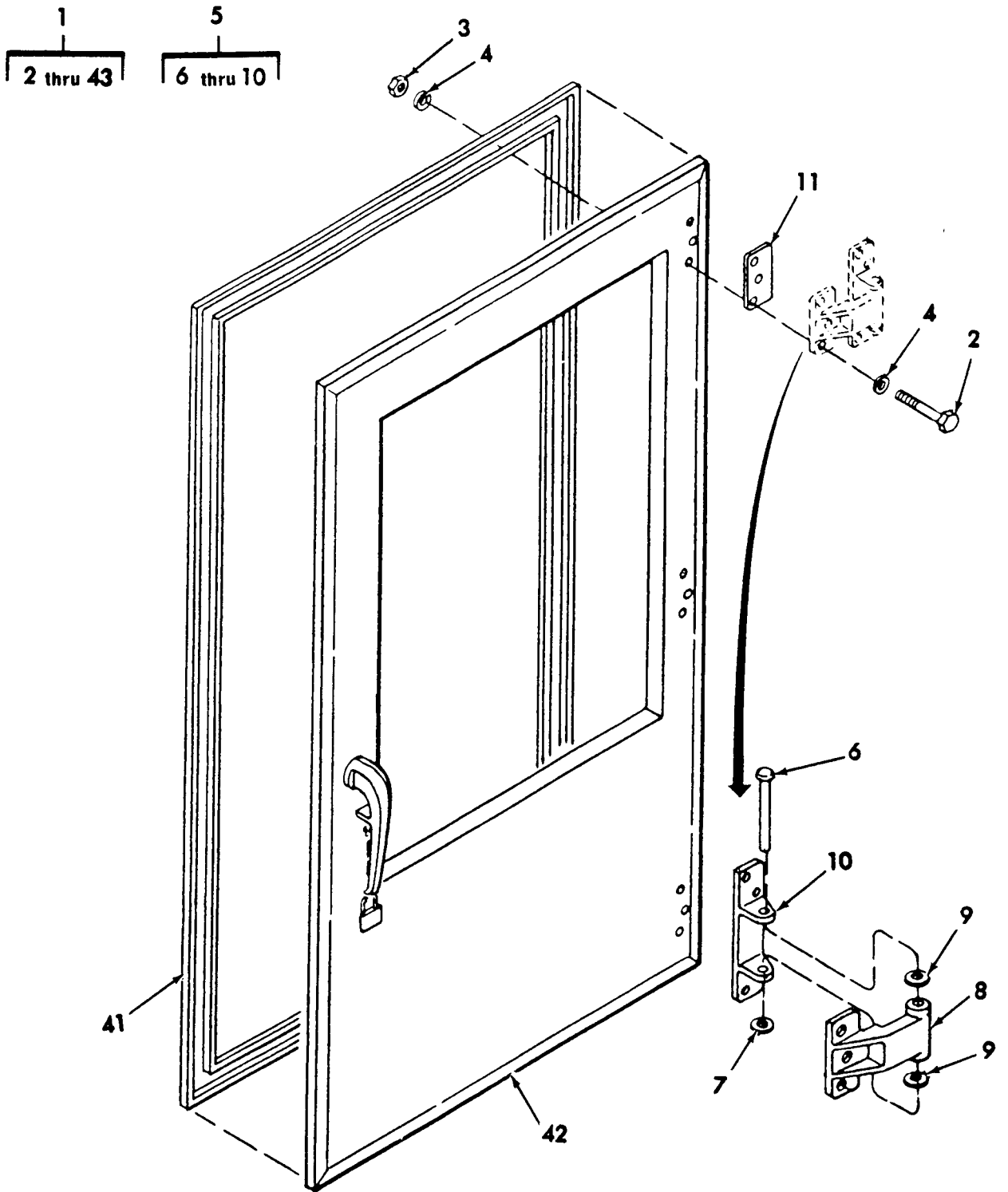

Figure 2. Outer Door Assembly (Sheet 1 of 2)

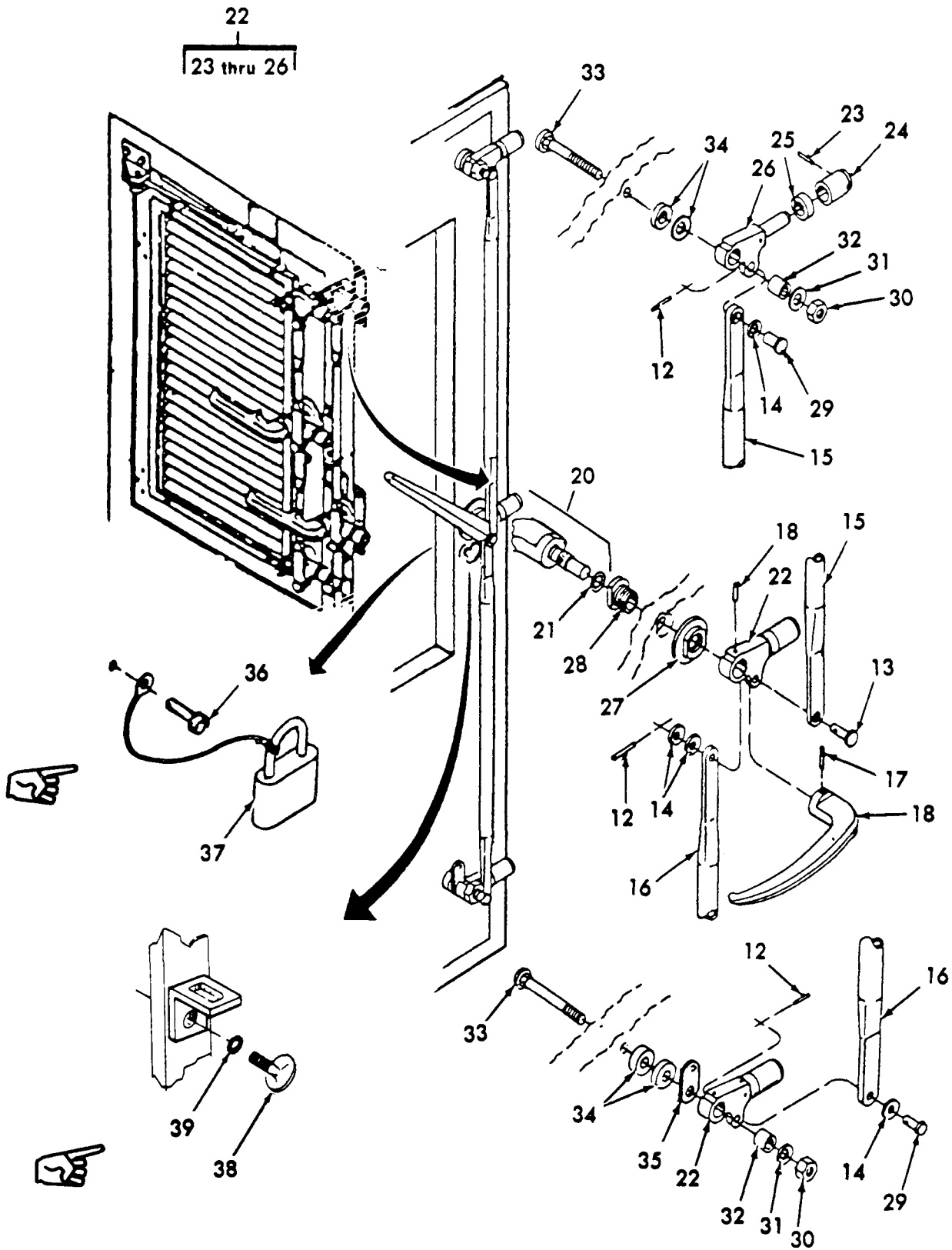

Figure 2. Outer Door Assembly (2 of 2 Sheets)

SECTION II (1) ITEM NO	(2) SMR CODE	(3) CAGEC	TM10-5411-205-23P (4) PART NUMBER	(5) DESCRIPTION AND USABLE ON CODES (UOC)	(6) QTY
GROUP 01 OUTER DOOR ASSEMBLY					
FIG. 2 OUTER DOOR ASSEMBLY					
1	PFOOO	81337	SM-D-208679	OUTER DOOR ASSY	1
2	PAOZZ	96906	MS35307-318	.SCREW,CAP,HEXAGON H	9
3	PAOZZ	96906	MS16228-4C	.NUT,SELF-LOCKING,HE	9
4	PAOZZ	96906	MS35333-74	.WASHER,LOCK	18
5	PAOOO	81337	SM-C-563520	.HINGE ASSY	3
6	PAOZZ	81337	SM-B-563523	..PIN	1
7	PAOZZ	88044	AN960C416L	..WASHER,FLAT	1
8	PAOZZ	81337	SM-C-563522	..HINGE,LEAF	1
9	PAOZZ	96906	MS15795-815	..WASHER,FLAT	2
10	PAOZZ	81337	SM-C-563521	..BRACKET	1
11	XBOZZ	81337	SM-B-435933	.SHIM,LAMINATED	V
12	PAOZZ	96906	MS171530	.PIN,SPRING	3
13	PAOZZ	96906	MS9466-18	.PIN,STRAIGHT,HEADED	1
14	PAOZZ	80063	SMB435902	.WASHER,FLAT	4
15	XDOZZ	81337	SM-D-563202 GRIV	.ROD LATCH ASSY	1
16	XDOZZ	81337	SM-D-563202 GRII I	.ROD LATCH ASSY	1
17	PAOZZ	96906	MS171659	.PIN,SPRING	1
18	PAOZZ	19220	AL-15818	.HANDLE,DOOR	1
19	PAOZZ	96906	MS35674-41	.PIN,GROOVED,HEADLES	1
20	PAOZZ	80063	SMB208663	.HANDLE ASSEMBLY	1
21	PAOZO	96906	MS29513-115	..PACKING,PREFORMED	1
22	PAOOO	81337	SC-C-200141	.LATCH ARM ASSY	3
23	XAOZZ	96906	MS171528	..PIN,SPRING	1
24	XAOZZ	81337	SC-B-200143	..ROLLER LATCH	1
25	XAOZZ	81337	SC-B-200144	..ROLLER EXTENSION	1
26	XAOZZ	81337	SC-C-200142	..ARM LATCH	1
27	PAOZZ	81337	SC-B-200150	.NUT,BEARING SLEEVE	1
28	PAOZZ	81337	SC-B-200151	.SLEEVE,HANDLE SHAFT	1
29	PAOZZ	96906	MS9466-13	.PIN,STRAIGHT,HEADED	2
30	PAOZZ	96906	MS16228-10C	.NUT,SELF-LOCKING,HE	2
31	PAOZZ	81337	SC-B-200146	.WASHER	2
32	PAOZZ	81337	SC-B-200145	.SPACER	2
33	PAOZZ	96906	MS35751-163	.BOLT	2
34	PAOZZ	80063	SMB615259-1	.SPACER,PLATE	V
35	PAOZZ	81337	SC-B-595073	.DETENT,LATCH ARM	1
36	PAOZZ	07707	AD62H	.RIVET,BLIND	1
37	PAOZZ	81337	SC-C-595537	.PADLOCK & KEY INCLUDES MOUNTING CABLE	1
38	PAOZZ	80063	SMB208666	.THUMBSCREW	1
39	PAOZZ	00770	30-401518	.WASHER,CRIMP MESH	1
40	PAOZZ	80063	SM-B-650093	.EYE,PADLOCK	1
41	PAOZZ	81337	SM-C-564839	.GASKET	1
42	PFOZZ	81337	SM-D-208680	.OUTER DOOR SUBASSY	1

END OF FIGURE

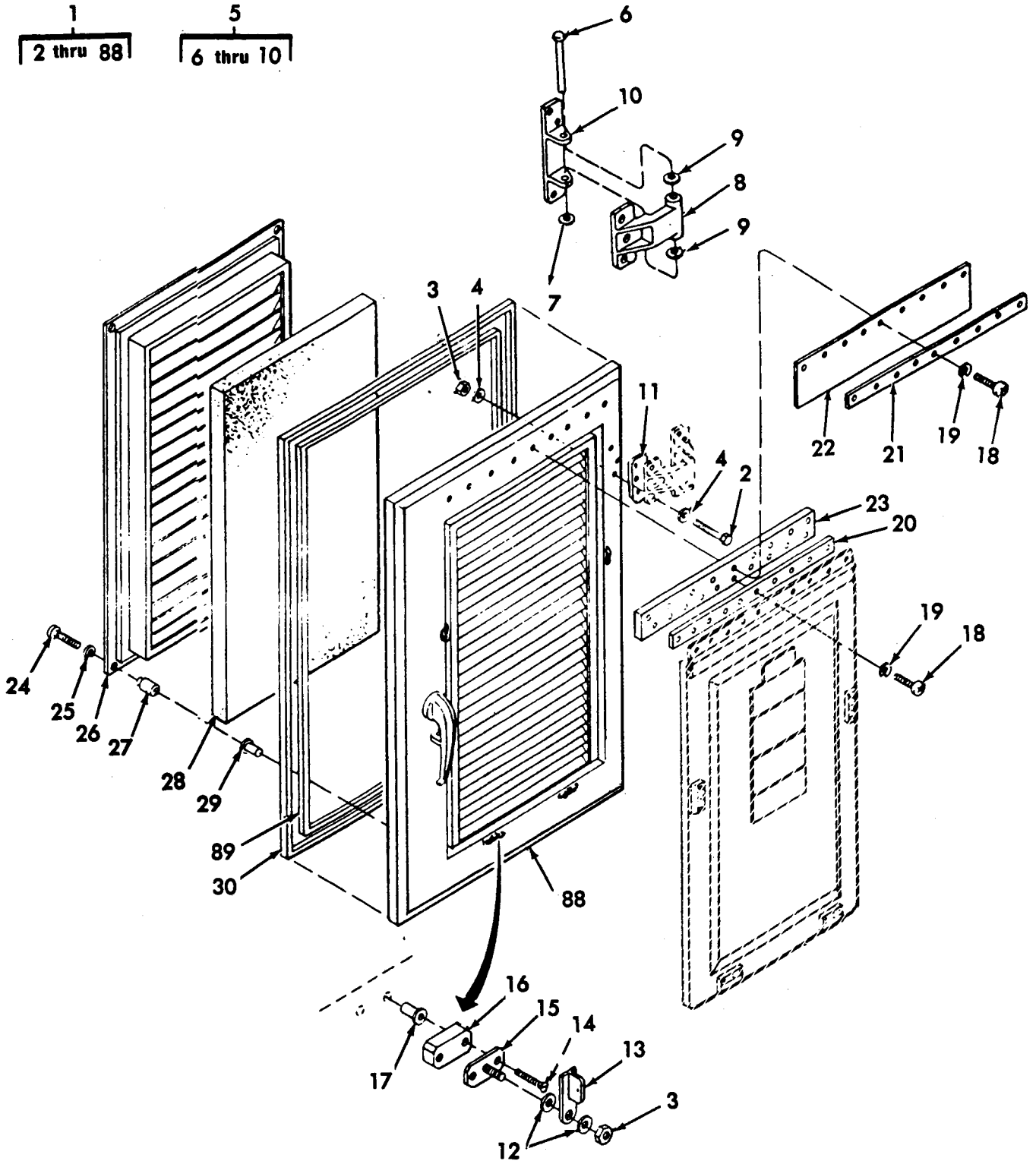

Figure 3. Inner Door Assembly (Sheet 1 of 4)

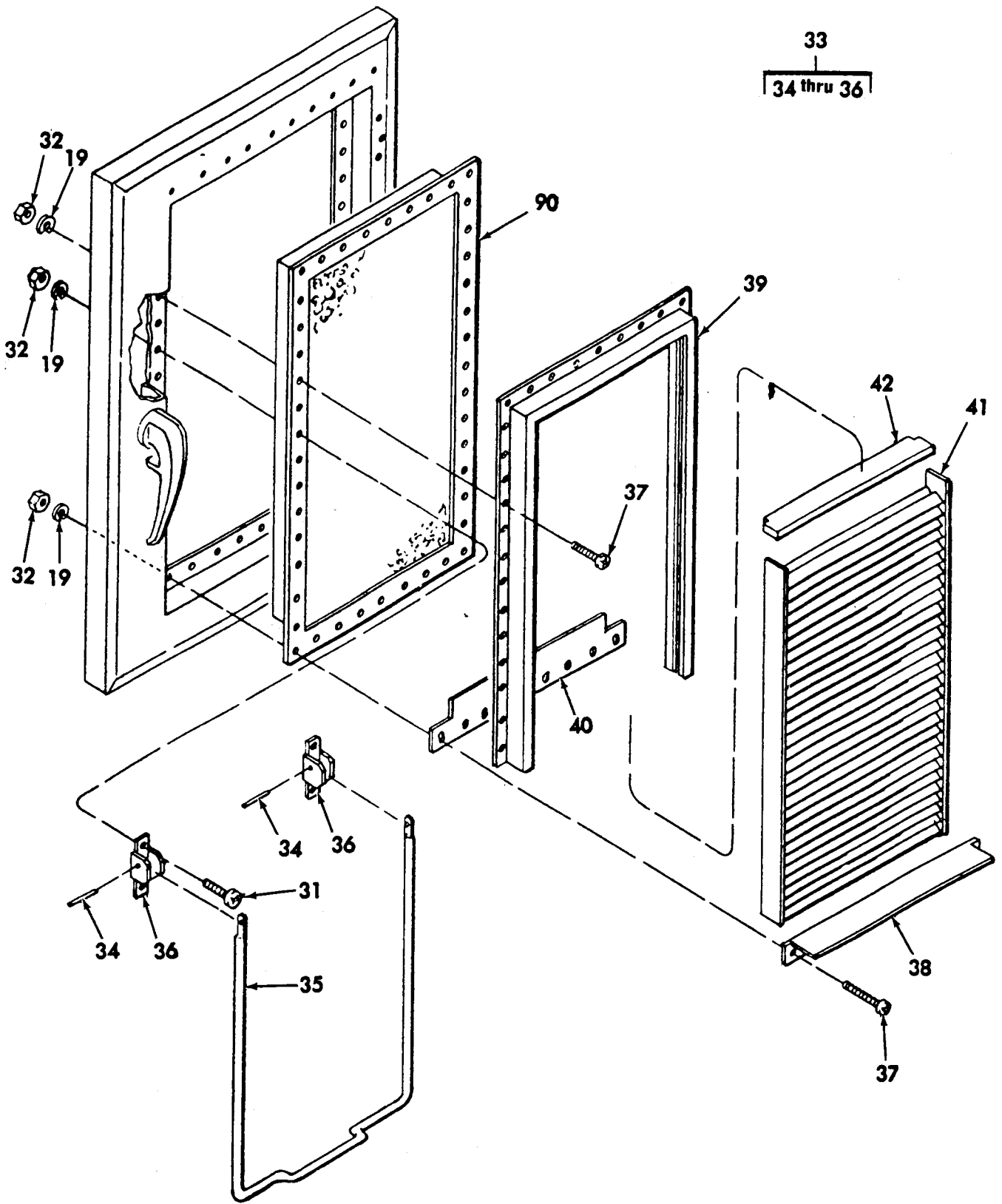

Figure 3. Inner Door Assembly (Sheet 2 of 4)

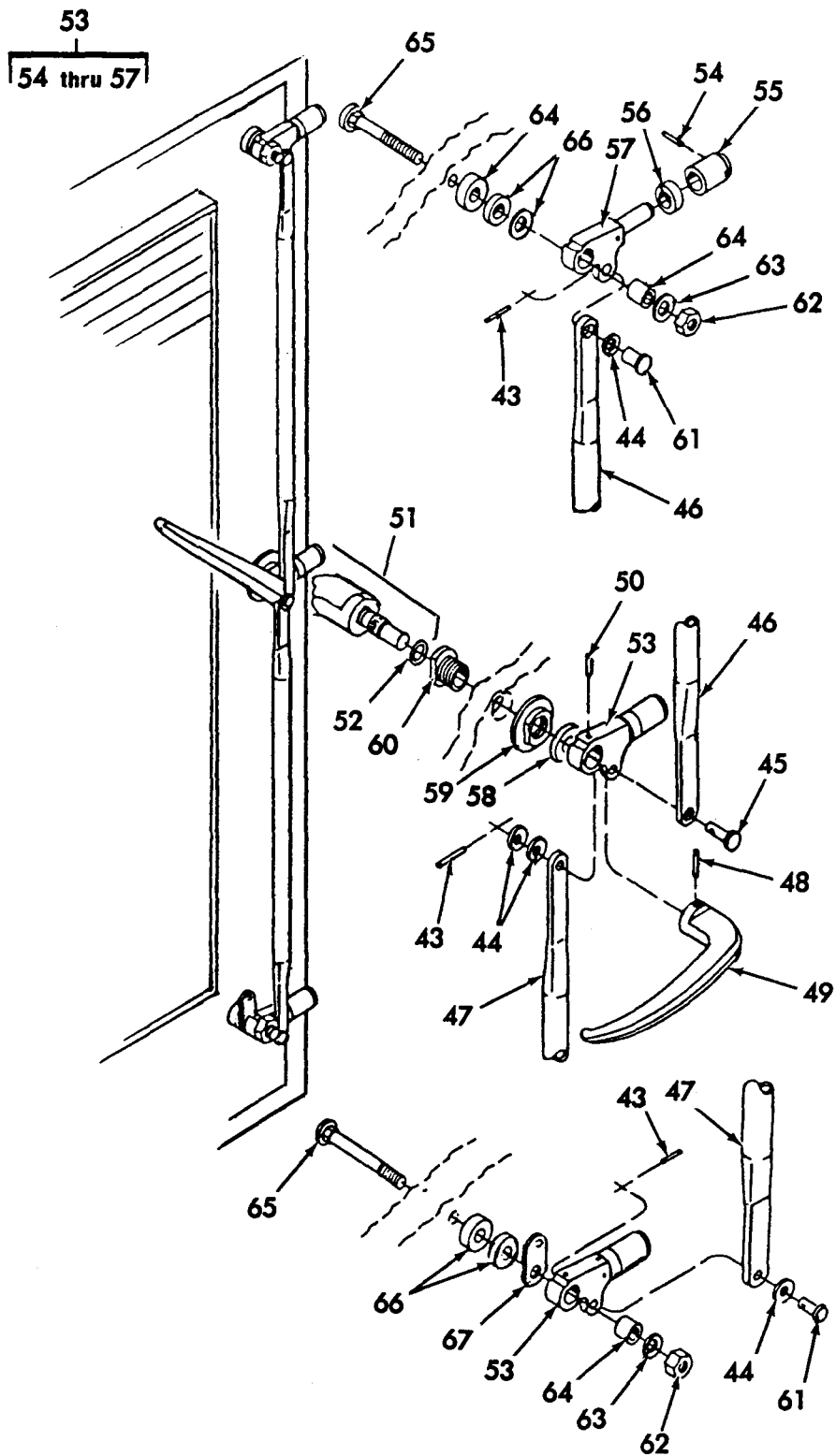

Figure 3. Inner Door Assembly (Sheet 3 of 4)

68
69 thru 87

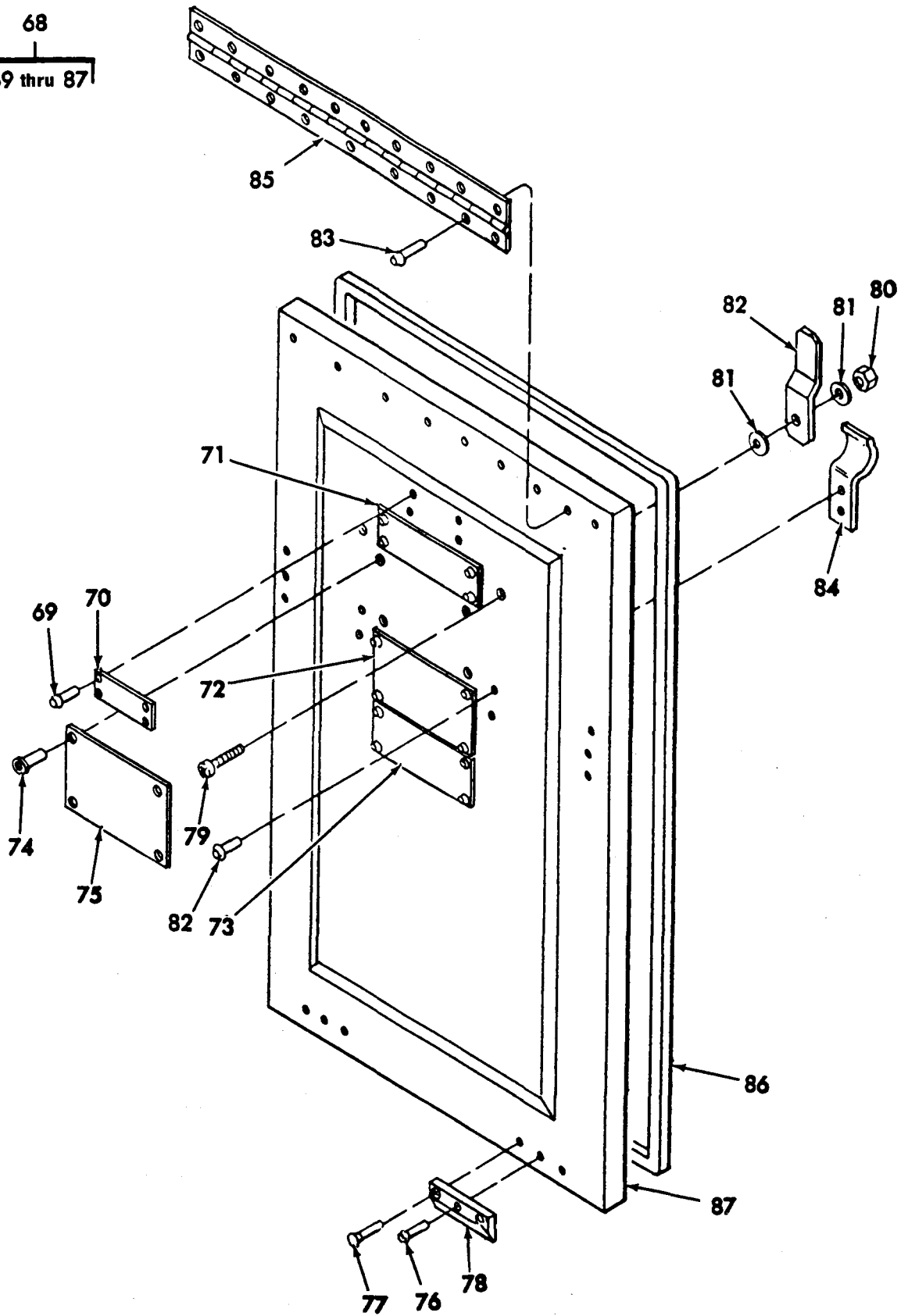

Figure 3. Inner Door Assembly (Sheet 4 of 4)

SECTION II		CHANGE 1				
(1)	(2)	(3)	(4)	(5)		(6)
ITEM NO	SMR CODE	CAGEC	PART NUMBER	DESCRIPTION AND USABLE ON CODES (UOC)		QTY
GROUP 02 INNER DOOR ASSEMBLY						
FIG. 3 INNER DOOR ASSEMBLY						
1	PFOOO	81337	SM-D-208682	INNER DOOR ASSY		1
2	PAOZZ	96906	MS35307-318	.SCREW,CAP,HEXAGON H		6
3	PAOZZ	96906	MS16228-4C	.NUT,SELF-LOCKING,HE		10
4	PAOZZ	96906	MS35333-74	.WASHER,LOCK		12
5	PAOZZ	81337	SM-C-563520	.HINGE ASSY		2
6	PAOZZ	81337	SM-B-563523	..PIN		1
7	PAOZZ	88044	AN960C416L	..WASHER,FLAT		1
8	PAOZZ	81337	SM-C-563522	..HINGE,LEAF		1
9	PAOZZ	96906	MS15795-815	..WASHER,FLAT		2
10	PAOZZ	81337	SM-C-563521	..BRACKET		1
11	PAOZZ	80063	SMB359933	.SHIM		V
12	PAOZZ	81337	SM-D-208682-5	.WASHER,FLAT		8
13	PAOZZ	81337	SM-B-450447	.LATCH		4
14	PAOZZ	96906	MS35190-257	.SCREW,MACHINE		8
15	PAOZZ	80063	SM-B-435927	.STUD PLATE ASSEMBLY		4
16	PAOZZ	80063	SMB435941	.SPACER,PLATE		4
17	PAOZZ	03487	S8B106	.NUT,BLIND,RIVET		8
18	PAOZZ	96906	MS24629-52	.SCREW,TAPPING,THREA		20
19	PAOZZ	96906	MS35338-43	.WASHER,LOCK		64
20	PAOZZ	81337	SC-B-595543	.SHIM,COVER		1
21	PAOZZ	80063	SM-B-435942	.PLATE,MENDING		1
22	PAOZZ	81337	SM-B-435943	.SHIELD		1
23	PAOZZ	80063	SMB435944	.SPACER,PLATE		1
24	PAOZZ	96906	MS51957-50	.SCREW,MACHINE		4
25	PAOZZ	96906	MS35338-137	.WASHER,LOCK		4
26	XDOZZ	81337	SM-D-435907	.DIRECTIONAL VANES		1
27	PAOZZ	81337	SM-B-564836	..SPACER		4
28	PAOZZ	80063	SM-B-435924	.FILTER MEDIA,AIR CO		1
29	PAOZZ	03481	S8B201	.NUT,BLIND RIVET		4
30	PAOZZ	81337	SM-C-564839	.GASKET		V
31	PAOZZ	96906	MS35191-274	.SCREW,MACHINE		4
32	PAOZZ	96906	MS35650-302	.NUT,PLAIN,HEXAGON		44
33	XBOZZ	81337	SM-D-435912	.HOLDER ASSY		1
34	PAOZZ	73957	GP24-125X0625-50	..GROOVE PIN		2
35	XBOZZ	81337	SM-D-435932	..HOLDER		1
36	XBOZZ	81337	SM-C-208692	..BRACKET ASSY		2
37	PAOZZ	96906	MS35207-264	.SCREW,MACHINE		40
38	XDOZZ	81337	SM-C-435908-2	.FRAME		1
39	XDOZZ	81337	SM-D-435931	.FRAME ASSY		1
40	XDOZZ	81337	SM-C-650094	.SHIELD		1
41	XBOZZ	81337	SM-C-435928	.LOUVER ASSY		1
42	PAOZZ	80063	SMB435938	.RUBBER STRIP		1
43	PAOZZ	96906	MS171530	.PIN,SPRING		3
44	PAOZZ	80063	SMB435902	.WASHER,FLAT		4
45	PAOZZ	81337	SM-B-435903-2	.PIN		1
46	XDOZZ	81337	SM-D-563202 GRVI	.ROD LATCH ASSY		1
			I			
47	XDOZZ	81337	SM-D-563202 GRV	.ROD LATCH ASSY		1

SECTION II

TM10-5411-205-23P

(1) ITEM NO	(2) SMR CODE	(3) CAGEC	(4) PART NUMBER	(5) DESCRIPTION AND USABLE ON CODES (UOC)	(6) QTY
48	PAOZZ	96906	MS171659	PIN, SPRING	1
49	PAOZZ	80063	SMC208678-3	HANDLE, DOOR	1
50	PAOZZ	96906	MS35674-41	PIN, GROOVED, HEADLES	1
51	PAOZZ	80063	SMB208663	HANDLE ASSEMBLY	1
52	PAOZZ	96906	MS29513-115	PACKING, PREFORMED	1
53	PAOOO	81337	SC-C-200141	LATCH ARM ASSY	3
54	XAOZZ	96906	MS171528	PIN, SPRING	1
55	XAOZZ	81337	SC-B-200143	ROLLER LATCH	1
56	XAOZZ	81337	SC-B-200144	ROLLER EXTENSION	1
57	XAOZZ	81337	SC-C-200142	ARM LATCH	1
58	PAOZZ	80063	SMB208670	SPACER, SLEEVE	1
59	PAOZZ	81337	SC-B-200150	NUT, BEARING SLEEVE	1
60	PAOZZ	81337	SC-B-200151	SLEEVE, HANDLE SHAFT	1
61	PAOZZ	81337	SM-B-435903-1	PIN, STRAIGHT, HEADED	2
62	PAOZZ	96906	MS16228-10C	NUT, SELF-LOCKING, HE	2
63	PAOZZ	81337	SC-B-200146	WASHER	2
64	PAOZZ	81337	SC-B-200145	SPACER	2
65	PAOZZ	96906	MS35751-164	BOLT, SQUARE NECK	2
66	PAOZZ	81337	SC-B-615259	SPACER, RING	V
67	PAOZZ	81337	SC-B-595073	DETENT, LATCH ARM	1
68	PAOOO	81337	SM-D-435911	LOUVER COVER ASSY	1
69	PAOZZ	07707	AD42H	RIVET, BLIND	16
70	XBOZZ	81337	SM-C-564810	PLATE, INSTRUCTION	1
71	XBOZZ	81337	SM-B-947239	PLATE, PAINT INSTR	1
72	XBOZZ	81337	SM-C-435936	PLATE, TRANSPORT	1
73	XBOZZ	81337	SM-C-435937	NAMEPLATE	1
				UOC:ETT	
73	XBOZZ	81337	SM-C-650125	NAMEPLATE	1
				UOC:ETU	
74	PAOZZ	03481	S58B161	NUT, BLIND RIVET	4
75	XAOZZ	81337	SM-C-435935	PLATE, TRASPORT	1
76	PAOZZ	07707	AD44H	RIVET, BLIND	4
77	PAOZZ	07707	AK44H	RIVET, BLIND	8
78	PAOZZ	80063	SMB450457	PLATE, MENDING	4
79	PAOZZ	96906	MS35206-280	SCREW, MACHINE	2
80	PAOZZ	96906	MS16228-4C	NUT, SELF-LOCKING, HE	2
81	PAOZZ	81337	SM-D-435911-2	WASHER, FLAT	4
82	PAOZZ	81337	SM-B-435910	CLIP	2
83	PAOZZ	07707	AD64H	RIVET, BLIND	17
84	PAOZZ	81337	SM-B-208694	CLIP	4
85	PAOZZ	81337	SM-B-208693	HINGE	1
86	MOOZZ	81337	SM-C-564839	GASKET, SILICONE	V
87	PAOZZ	80063	SMC435913	LOUVER COVER	1
88	PFOZZ	80063	SMD208683	INNER DOOR SUBASSY	1
89	MOOZZ	07700	21-43151	SHIELD EM	V
				UOC:ETU	
90	PAOZZ	81337	SM-C-435909	EM FILTER MODIFIED	1
				UOC:ETU	

END OF FIGURE

1
2 thru 9

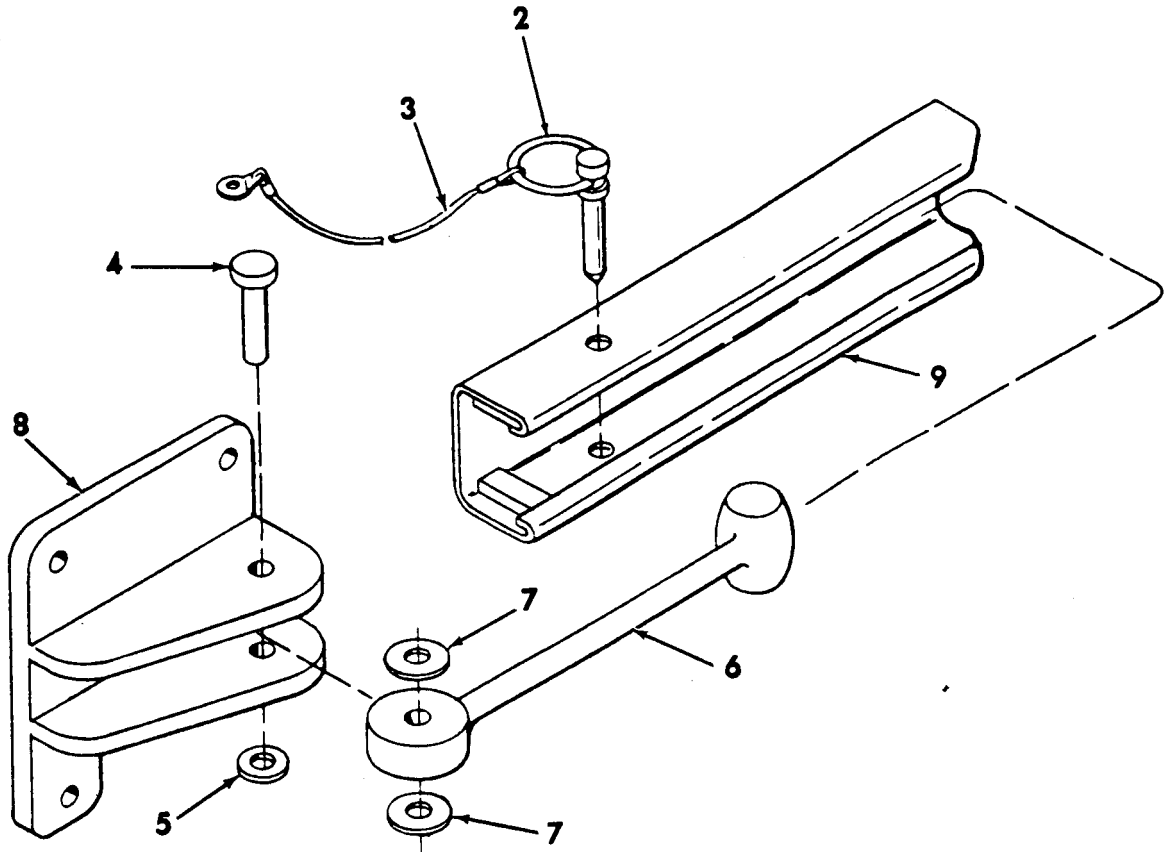

Figure 4. Door Stay Assembly

SECTION (1)	4-1 (2)		TM10-5411-205-23P (4)	(5)	(6)
ITEM NO	SMR CODE	CAGEC	PART NUMBER	DESCRIPTION AND USABLE ON CODES (UOC)	QTY
				GROUP 03 DOOR STAY ASSEMBLY	
				FIG. 4 DOOR STAY ASSEMBLY	
1	PAOOO	81337	SM-D-435914	DOOR STAY ASSY	1
2	PAOZZ	84256	53679-1	.RING & PIN ASSY	1
3	PAOZZ	81982	53679	.SPACER	1
4	PAOZZ	80063	SMB435919	.PIN, SHOULDERED, HEADED	1
5	PAOZZ	88044	AN960C416L	.WASHER, FLAT	1
6	XAOZZ	81337	SM-B-781196	.ROD, DOOR STAY	1
7	PAOZZ	80063	SM-B-435923	.WASHER, FLAT	2
8	XAOZZ	81337	SM-C-435920	.BRACKET	1
9	XAOZZ	81337	SM-C-435918	.CHANNEL ASSY	1
				END OF FIGURE	

1
2 thru 14

2
4 thru 8

9
10 thru 14

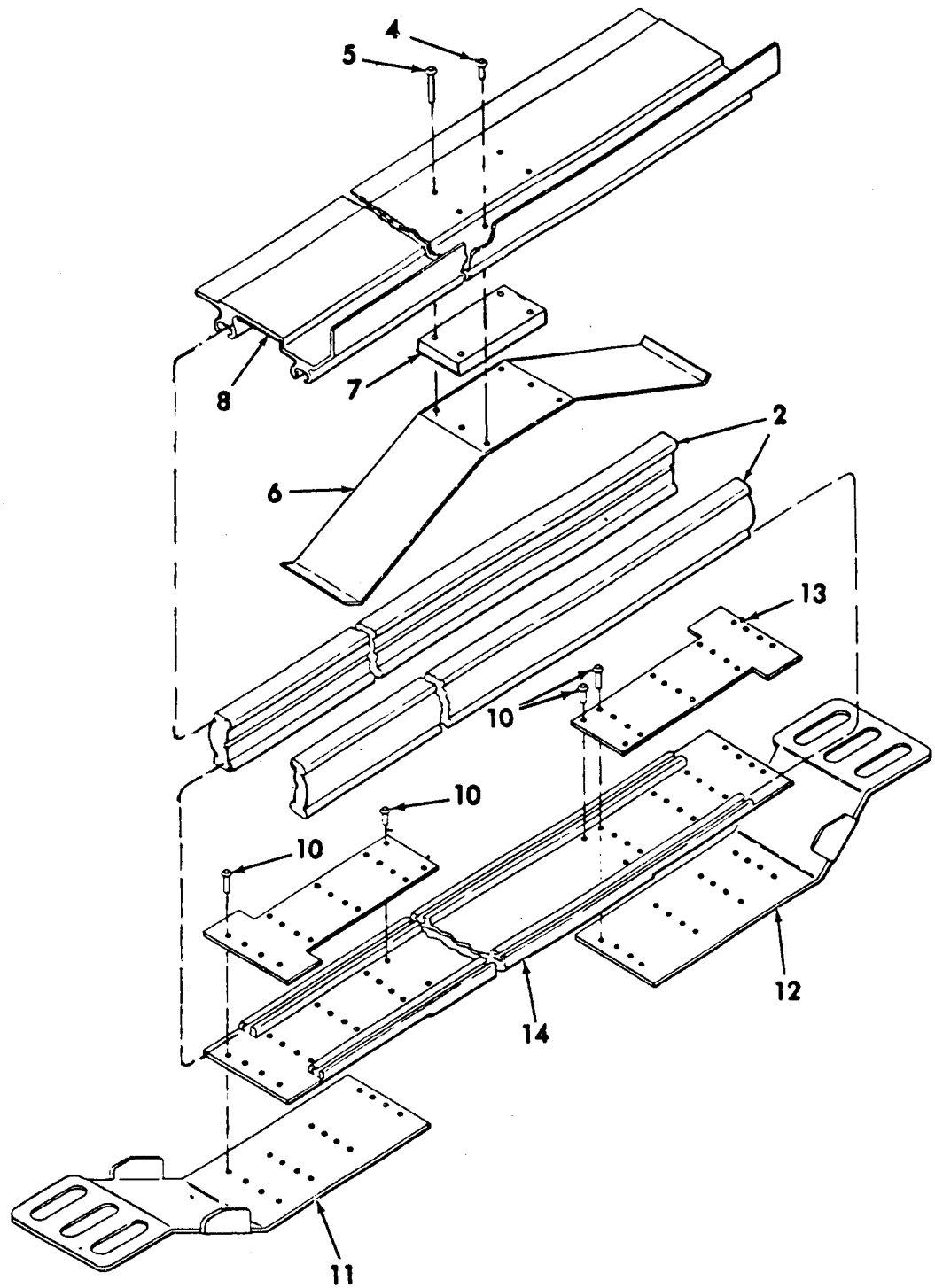

Figure 5. Skid Assembly

SECTION II (1)	ITEM (2)	SMR (3)	TM10-5411-205-23P (4)	(5)	(6)
NO	CODE	CAGEC	PART NUMBER	DESCRIPTION AND USABLE ON CODES (UOC)	QTY
GROUP 04 SKID ASSEMBLY					
FIG. 5 SKID ASSEMBLY					
1	XBOOO	81337	SM-C-650082	SKID ASSY	1
2	PAOZZ	81337	SM-C-563635	.SKIRT	2
3	XAOZZ	81337	SM-C-650046	.UPPER PLATE ASSY	1
4	XDOZZ	07707	AK66H	..RIVET,BLIND	2
5	PAOZZ	80063	SM-C-563698-9	..RIVET,BLIND	4
6	XAOZZ	81337	SM-C-563539	..SPRING	1
7	XAOZZ	81337	SM-B-563542	..SPACER	1
8	XAOZZ	81337	SM-D-650047	..PLATE,SKID	1
9	XAOZZ	81337	SM-D-563645	.NOSE PLATE ASSY	1
10	PAOZZ	80205	NAS1399MW6-5	..RIVET,BLIND	36
11	XAOZZ	81337	SM-C-563646-1	..NOSEPLATE	1
12	XAOZZ	81337	SM-C-563646-2	..NOSEPLATE	1
13	XAOZZ	81337	SM-B-563648	..PLATE	2
14	XAOZZ	81337	SM-C-563647	..SHOE	1
END OF FIGURE					

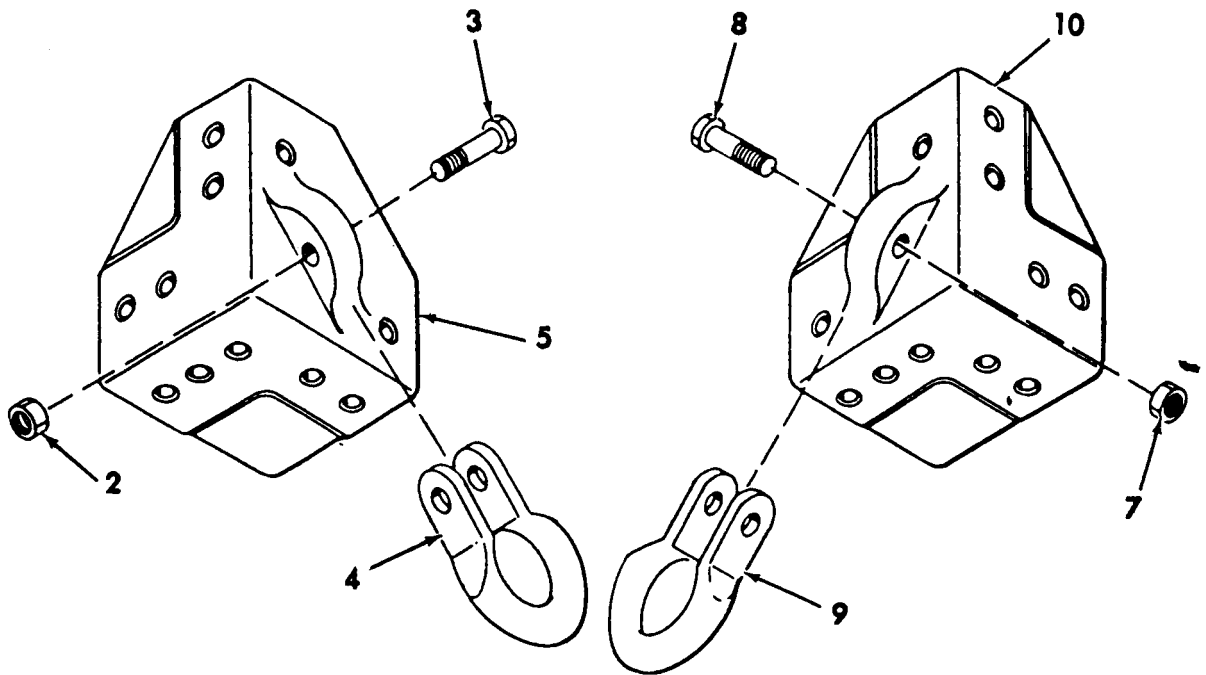
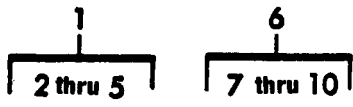

Figure 6. Towing Bracket Assembly

SECTION II				TM10-5411-205-23P	
(1)	(2)	(3)	(4)	(5)	(6)
ITEM NO	SMR CODE	CAGEC	PART NUMBER	DESCRIPTION AND USABLE ON CODES (UOC)	QTY
GROUP 05 TOWING BRACKET ASSEMBLY					
FIG. 6 TOWING BRACKET ASSEMBLY					
1	XAOFF	81337	SM-C-349315 GRI	TOWING BRACKET ASSY	2
2	PAOZZ	96906	MS21044N7	.NUT, SELF-LOCKING, HE	1
3	PAOZZ	88044	AN7C-22A	.BOLT, MACHINE	1
4	PAOZZ	80063	SMB165462	.CLAMP, MATERIAL LIFT	1
5	XAOFF	81337	SM-D-349314	.BRACKET	1
6	XAOFF	81337	SM-C-349315 GRII	TOWING BRACKET ASSY	2
7	PAOZZ	96906	MS21044N7	.NUT, SELF-LOCKING, HE	1
8	PAOZZ	88044	AN7C-22A	.BOLT, MACHINE	1
9	PAOZZ	80063	SMB165462	.CLAMP, MATERIAL LIFT	1
10	XAOFF	81337	SM-D-349313	.BRACKET	1
END OF FIGURE					

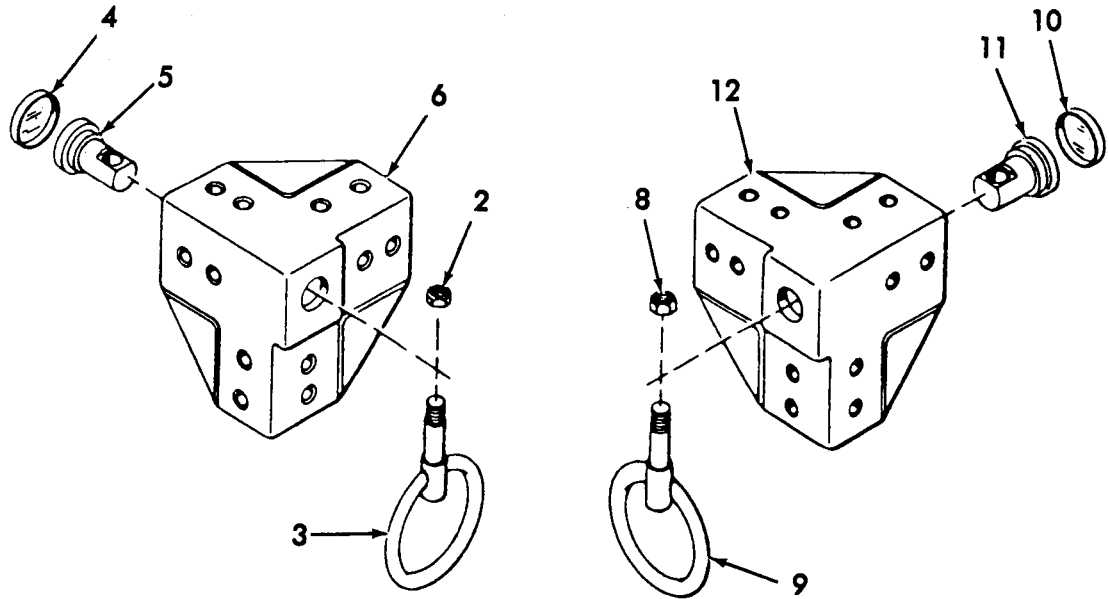
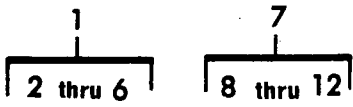

Figure 7. Lifting Bracket Assembly

SECTION II		TM10-5411-205-23P			
(1)	(2)	(3)	(4)	(5)	(6)
ITEM	SMR		PART		
NO	CODE	CAGEC	NUMBER	DESCRIPTION AND USABLE ON CODES (UOC)	QTY
GROUP 06 LIFTING BRACKET ASSEMBLY					
FIG. 7 LIFTING BRACKET ASSEMBLY					
1	XAOFF	81337	SM-C-650075 GRI	LIFTING BRACKET ASY	2
2	PAOZZ	96906	MS21044-N10	.NUT,SELF-LOCKING,HE	1
3	PAOZZ	80063	SM-C-563721	.RING ASSY	1
4	XAOFF	81337	SC-B-865355	.CAP, LIFTING EYE	1
5	XAOFF	81337	SM-B-563516	.PIN	1
6	XAOFF	81337	SM-D-650083-1	.BRACKET	1
7	XAOFF	81337	SM-C-650075 GRII	LIFTING BRACKET ASY	2
8	PAOZZ	96906	MS21044-N10	.NUT,SELF-LOCKING,HE	1
9	PAOZZ	80063	SM-C-563721	.RING ASSY	1
10	XAOFF	81337	SC-B-865355	.CAP, LIFTING EYE	1
11	XAOFF	81337	SM-B-563516	.PIN	1
12	XAOFF	81337	SM-D-650083-2	.BRACKET	1
END OF FIGURE					

Section III. SPECIAL TOOLS LIST

(Not Applicable)

CROSS-REFERENCE INDEXES

NATIONAL STOCK NUMBER INDEX

STOCK NUMBER	FIG.	ITEM	STOCK NUMBER	FIG.	ITEM
5340-00-006-2358	3	49	5310-00-515-7449	4	5
5365-00-007-0138	1	21	5310-00-543-2740	1	34
5305-00-008-7868	2	38		2	4
5315-00-008-9066	3	61		3	4
5315-00-008-9068	4	4	5330-00-545-5221	2	41
5315-00-008-9075	2	13		3	30
5305-00-021-3668	1	40	5305-00-579-5238	1	59
5310-00-045-3296	3	19	5310-00-582-5965	1	9
5305-00-052-6919	3	18	5306-00-584-4911	6	3
5305-00-054-6675	3	24		6	8
5315-00-062-5417	2	19	5310-00-595-6057	2	9
	3	50		3	9
5320-00-070-2094	5	10	5305-00-655-6974	1	33
5305-00-071-1318	1	55	5305-00-702-9070	1	39
5305-00-082-6721	1	54		2	2
5310-00-088-0552	6	2		3	2
	6	7	5310-00-763-0349	1	57
5340-00-116-1510	2	20	5310-00-809-4058	1	41
	3	51	5315-00-846-8337	2	17
5340-00-116-5796	3	78		3	48
5340-00-118-0018	3	13	5320-00-882-8386	1	23
4510-00-121-6096	1	17		3	76
5365-00-134-3251	3	11	5310-00-883-9417	1	25
4130-00-143-9211	3	28	5305-00-889-3000	1	8
5305-00-147-3224	1	30	5410-00-919-4958	1	12
5365-00-173-7010	2	34	5310-00-929-6452	1	28
5330-00-179-9225	3	42	5320-00-932-1972	3	69
5670-00-182-8475	3	87	3940-00-933-4474	6	4
5670-00-182-8476	3	88		6	9
4730-00-196-1495	1	26	5310-00-934-9751	3	32
5305-00-207-8253	1	24	5320-00-956-7355	1	5
5310-00-245-8825	1	35		3	83
	2	3	5320-00-956-7362	2	36
	3	3	5305-00-958-5481	3	14
	3	80	5340-00-974-9847	2	18
5310-00-245-8826	2	30	5310-00-982-6809	7	2
	3	62		7	8
5330-00-248-3847	2	21	5305-00-984-7342	3	31
	3	52	5305-00-988-1724	3	79
5365-00-263-9561	3	16	5305-00-989-7435	3	37
5365-00-263-9569	3	23	5315-01-049-1773	2	12
5365-00-263-9576	3	58		3	43
5306-00-268-2440	3	65	5340-01-065-8967	2	40
5365-00-270-7281	1	37	5340-01-091-7083	2	10
5365-00-270-7282	1	38		3	10
5310-00-279-9026	2	14	5365-01-102-9624	4	3
	3	44	5340-01-137-9055	3	21
5320-00-420-2169	3	77	5410-01-140-0452	3	15
5310-00-515-7449	2	7	5310-01-151-5131	4	7
	3	7	5320-01-180-2566	5	5

CROSS-REFERENCE INDEXES

NATIONAL STOCK NUMBER INDEX

STOCK NUMBER	FIG.	ITEM	STOCK NUMBER	FIG.	ITEM
5340-01-239-8427	1	42			
5365-01-294-9467	1	36			

CROSS-REFERENCE INDEXES

CAGEC	PART NUMBER	PART NUMBER INDEX STOCK NUMBER	FIG.	ITEM
07707	AD42H	5320-00-932-1972	3	69
07707	AD44H	5320-00-882-8386	1	23
			3	76
07707	AD62H	5320-00-956-7362	2	36
07707	AD64H	5320-00-956-7355	1	5
			3	83
07707	AK44H	5320-00-420-2169	3	77
07707	AK66H		5	4
19220	AL-15818	5340-00-974-9847	2	18
19220	AL1-575709		1	10
19220	AL1-6040		1	13
81352	AN504-8R12		1	1
81352	AN504C-1032R8		1	16
88044	AN7C-22A	5306-00-584-4911	6	3
			6	8
88044	AN960C416L	5310-00-515-7449	2	7
			3	7
			4	5
73957	GP24-125X0625-50		3	34
81349	MIL-C-5424		1	47
96906	MS15795-815	5310-00-595-6057	2	9
			3	9
96906	MS16228-10C	5310-00-245-8826	2	30
			3	62
96906	MS16228-4C	5310-00-245-8825	1	35
			2	3
			3	3
			3	80
96906	MS171528		2	23
			3	54
96906	MS171530	5315-01-049-1773	2	12
			3	43
96906	MS17160-108		1	29
96906	MS171659	5315-00-846-8337	2	17
			3	48
96906	MS21044-N10	5310-00-982-6809	7	2
			7	8
96906	MS21044N7	5310-00-088-0552	6	2
			6	7
96906	MS24629-52	5305-00-052-6919	3	18
96906	MS24667-31		1	60
96906	MS24667-42		1	61
96906	MS27131-51	5310-00-763-0349	1	57
96906	MS27183-10	5310-00-809-4058	1	41
96906	MS29513-115	5330-00-248-3847	2	21
			3	52
96906	MS35190-257	5305-00-958-5481	3	14
96906	MS35191-274	5305-00-984-7342	3	31
96906	MS35206-230	5305-00-889-3000	1	8
96906	MS35206-280	5305-00-988-1724	3	79
96906	MS35207-264	5305-00-989-7435	3	37

CROSS-REFERENCE INDEXES

CAGEC	PART NUMBER	PART NUMBER INDEX STOCK NUMBER	FIG.	ITEM
96906	MS35307-308	5305-00-207-8253	1	24
96906	MS35307-309	5305-00-579-5238	1	59
96906	MS35307-310	5305-00-021-3668	1	40
96906	MS35307-315	5305-00-655-6974	1	33
96906	MS35307-318	5305-00-702-9070	1	39
			2	2
			3	2
96906	MS35333-74	5310-00-543-2740	1	34
			2	4
			3	4
96906	MS35338-137		3	25
96906	MS35338-158	5310-00-883-9417	1	25
96906	MS35338-43	5310-00-045-3296	3	19
96906	MS35338-44	5310-00-582-5965	1	9
96906	MS35650-302	5310-00-934-9751	3	32
96906	MS35674-41	5315-00-062-5417	2	19
			3	50
96906	MS35751-163		2	33
96906	MS35751-164	5306-00-268-2440	3	65
96906	MS51844-62		1	43
96906	MS51861-15C	5305-00-147-3224	1	30
96906	MS51953-80	4730-00-196-1495	1	26
96906	MS51957-50	5305-00-054-6675	3	24
96906	MS51957-81	5305-00-082-6721	1	54
96906	MS51957-83	5305-00-071-1318	1	55
96906	MS9466-13		2	29
96906	MS9466-18	5315-00-008-9075	2	13
96906	NAS1399MW6-5	5320-00-070-2094	5	10
76691	N1COPRESS 071-1		1	46
	Q			
81337	SC-B-200143		2	24
			3	55
81337	SC-B-200144		2	25
			3	56
81337	SC-B-200145		2	32
			3	64
81337	SC-B-200146		2	31
			3	63
81337	SC-B-200150		2	27
			3	59
81337	SC-B-200151		2	28
			3	60
81337	SC-B-595073		2	35
			3	67
81337	SC-B-595543		3	20
81337	SC-B-615259		3	66
81337	SC-B-781197	5340-01-239-8427	1	42
81337	SC-B-781198		1	44
81337	SC-B-781199		1	45
81337	SC-B-781203		1	48

CROSS-REFERENCE INDEXES

CAGEC	PART NUMBER	PART NUMBER INDEX STOCK NUMBER	FIG.	ITEM
81337	SC-B-865355		7	4
			7	10
81337	SC-C-200141		2	22
			3	53
81337	SC-C-200142		2	26
			3	57
81337	SC-C-595537		2	37
81337	SM-B-208693		3	85
81337	SM-B-208694		3	84
81337	SM-B-340031		1	31
81337	SM-B-374181		1	19
81337	SM-B-374182		1	20
81337	SM-B-435899-2		1	51
81337	SM-B-435903-1	5315-00-008-9066	3	61
81337	SM-B-435903-2		3	45
81337	SM-B-435910		3	82
80063	SM-B-435923	5310-01-151-5131	4	7
80063	SM-B-435924	4130-00-143-9211	3	28
80063	SM-B-435927	5410-01-140-0452	3	15
81337	SM-B-435933		2	11
80063	SM-B-435942	5340-01-137-9055	3	21
81337	SM-B-435943		3	22
81337	SM-B-450447	5340-00-118-0018	3	13
81337	SM-B-563516		7	5
			7	11
81337	SM-B-563518		1	22
81337	SM-B-563523		2	6
			3	6
81337	SM-B-563542		5	7
81337	SM-B-563545		1	52
81337	SM-B-563546		1	53
81337	SM-B-563648		5	13
81337	SM-B-564836		3	27
80063	SM-B-650093	5340-01-065-8967	2	40
81337	SM-B-650097		1	32
81337	SM-B-650105	5365-00-007-0138	1	21
80063	SM-B-650118	5365-01-294-9467	1	36
81337	SM-B-650122		1	50
81337	SM-B-781196		4	6
81337	SM-B-947239		3	71
81337	SM-C-208692		3	36
81337	SM-C-349315 GRI		6	1
81337	SM-C-349315 GRII		6	6
81337	SM-C-435904		1	49
81337	SM-C-435908-2		3	38
81337	SM-C-435909		3	90
81337	SM-C-435918		4	9
81337	SM-C-435920		4	8
81337	SM-C-435928		3	41
81337	SM-C-435935		3	75
81337	SM-C-435936		3	72

CROSS-REFERENCE INDEXES

CAGEC	PART NUMBER	PART NUMBER INDEX STOCK NUMBER	FIG.	ITEM
81337	SM-C-435937		3	73
81337	SM-C-563520		2	5
			3	5
81337	SM-C-563521	5340-01-091-7083	2	10
			3	10
81337	SM-C-563522		2	8
			3	8
81337	SM-C-563539		5	6
81337	SM-C-563619		1	6
81337	SM-C-563635		5	2
81337	SM-C-563646-1		5	11
81337	SM-C-563646-2		5	12
81337	SM-C-563647		5	14
80063	SM-C-563698-9	5320-01-180-2566	5	5
80063	SM-C-563721		7	3
			7	9
81337	SM-C-564810		3	70
81337	SM-C-564839	5330-00-545-5221	2	41
			3	30
			3	86
81337	SM-C-650046		5	3
81337	SM-C-650075 GRI		7	1
81337	SM-C-650075 GRII		7	7
81337	SM-C-650081-1		1	2
81337	SM-C-650081-2		1	3
81337	SM-C-650082		5	1
81337	SM-C-650094		3	40
81337	SM-C-650125		3	73
81337	SM-D-208679		2	1
81337	SM-D-208680		2	42
81337	SM-D-208682		3	1
81337	SM-D-208682-5		3	12
81337	SM-D-349313		6	10
81337	SM-D-349314		6	5
81337	SM-D-435907		3	26
81337	SM-D-435911		3	68
81337	SM-D-435911-2		3	81
81337	SM-D-435912		3	33
81337	SM-D-435914		4	1
81337	SM-D-435931		3	39
81337	SM-D-435932		3	35
81337	SM-D-563202 GRII		2	16
	I			
81337	SM-D-563202 GRIV		2	15
81337	SM-D-563202 GRV		3	47
81337	SM-D-563202 GRVI		3	46
	I			
81337	SM-D-563543		1	56
81337	SM-D-563645		5	9
81337	SM-D-650014		1	4
81337	SM-D-650015		1	7

CROSS-REFERENCE INDEXES

CAGEC	PART NUMBER	PART NUMBER INDEX STOCK NUMBER	FIG.	ITEM
81337	SM-D-650019		1	15
81337	SM-D-650047		5	8
81337	SM-D-650083-1		7	6
81337	SM-D-650083-2		7	12
80063	SMB165462	3940-00-933-4474	6	4
			6	9
80063	SMB208663	5340-00-116-1510	2	20
			3	51
80063	SMB208666	5305-00-008-7868	2	38
80063	SMB208670	5365-00-263-9576	3	58
80063	SMB359933	5365-00-134-3251	3	11
80063	SMB435902	5310-00-279-9026	2	14
			3	44
80063	SMB435919	5315-00-008-9068	4	4
80063	SMB435938	5330-00-179-9225	3	42
80063	SMB435941	5365-00-263-9561	3	16
80063	SMB435944	5365-00-263-9569	3	23
80063	SMB450457	5340-00-116-5796	3	78
80063	SMB615259-1	5365-00-173-7010	2	34
80063	SMB650102-1	5365-00-270-7281	1	37
80063	SMB650102-2	5365-00-270-7282	1	38
80063	SMC208678-3	5340-00-006-2358	3	49
80063	SMC435913	5670-00-182-8475	3	87
80063	SMD208683	5670-00-182-8476	3	88
03481	S25B151		1	14
03481	S25B211	5310-00-929-6452	1	28
03481	S25B320		1	62
03481	S25B451		1	58
03481	S31B425		1	63
03481	S58B161		3	74
03481	S8B201		3	29
19220	1-575709-50	5410-00-919-4958	1	12
19220	15949		1	11
07700	21-43151		3	89
73957	25020-12		1	27
00770	30-401518		2	39
81982	53679	5365-01-102-9624	4	3
84256	53679-1		4	2
59647	68505-2		1	18
59647	68505-3	4510-00-121-6096	1	17

CROSS-REFERENCE INDEXES

FIGURE AND ITEM NUMBER INDEX				
FIG.	ITEM	STOCK NUMBER	CAGEC	PART NUMBER
1	1		81352	AN504-8R12
1	2		81337	SM-C-650081-1
1	3		81337	SM-C-650081-2
1	4		81337	SM-D-650014
1	5	5320-00-956-7355	07707	AD64H
1	6		81377	SM-C-563619
1	7		81377	SM-D-650015
1	8	5305-00-889-3000	96906	MS35206-230
1	9	5310-00-582-5965	96906	MS35338-44
1	10		19220	AL1-575709
1	11		19220	15949
1	12	5410-00-919-4958	19220	1-575709-50
1	13		19220	AL1-6040
1	14		03481	S25B151
1	15		81337	SM-D-650019
1	16		81352	AN504C-1032R8
1	17	4510-00-121-6096	59647	68505-3
1	18		59647	68505-2
1	19		81337	SM-B-374181
1	20		81337	SM-B-374182
1	21	5365-00-007-0138	81337	SM-B-650105
1	22		81337	SM-B-563518
1	23	5320-00-882-8386	07707	AD44H
1	24	5305-00-207-8253	96906	MS35307-308
1	25	5310-00-883-9417	96906	MS35338-158
1	26	4730-00-196-1495	96906	MS51953-80
1	27		73957	25020-12
1	28	5310-00-929-6452	03481	S25B211
1	29		96906	MS17160-108
1	30	5305-00-147-3224	96906	MS51861-15C
1	31		81337	SM-B-340031
1	32		81337	SM-B-650097
1	33	5305-00-655-6974	96906	MS35307-315
1	34	5310-00-543-2740	96906	MS35333-74
1	35	5310-00-245-8825	96906	MS16228-4C
1	36	5365-01-294-9467	80063	SM-B-650118
1	37	5365-00-270-7281	80063	SMB650102-1
1	38	5365-00-270-7282	80063	SMB650102-2
1	39	5305-00-702-9070	96906	MS35307-318
1	40	5305-00-021-3668	96906	MS35307-310
1	41	5310-00-809-4058	96906	MS27183-10
1	42	5340-01-239-8427	81337	SC-B-781197
1	43		96906	MS51844-62
1	44		81337	SC-B-781198
1	45		81337	SC-B-781199
1	46		76691	N1COPRESS 071-1-Q
1	47		81349	MIL-C-5424
1	48		81337	SC-B-781203
1	49		81337	SM-C-435904
1	50		81337	SM-B-650122

CROSS-REFERENCE INDEXES

FIG.	ITEM	FIGURE AND ITEM NUMBER INDEX		PART NUMBER
		STOCK NUMBER	CAGEC	
1	51		81337	SM-B-435899-2
1	52		81337	SM-B-563545
1	53		81337	SM-B-563546
1	54	5305-00-082-6721	96906	MS51957-81
1	55	5305-00-071-1318	96906	MS51957-83
1	56		81337	SM-D-563543
1	57	5310-00-763-0349	96906	MS27131-51
1	58		03481	S25B451
1	59	5305-00-579-5238	96906	MS35307-309
1	60		96906	MS24667-31
1	61		96906	MS24667-42
1	62		03481	S25B320
1	63		03481	S31B425
2	1		81337	SM-D-208679
2	2	5305-00-702-9070	96906	MS35307-318
2	3	5310-00-245-8825	96906	MS16228-4C
2	4	5310-00-543-2740	96906	MS35333-74
2	5		81337	SM-C-563520
2	6		81337	SM-B-563523
2	7	5310-00-515-7449	88044	AN960C416L
2	8		81337	SM-C-563522
2	9	5310-00-595-6057	96906	MS15795-815
2	10	5340-01-091-7083	81337	SM-C-563521
2	11		81337	SM-B-435933
2	12	5315-01-049-1773	96906	MS171530
2	13	5315-00-008-9075	96906	MS9466-18
2	14	5310-00-279-9026	80063	SMB435902
2	15		81337	SM-D-563202 GRIV
2	16		81337	SM-D-563202 GRII I
2	17	5315-00-846-8337	96906	MS171659
2	18	5340-00-974-9847	19220	AL-15818
2	19	5315-00-062-5417	96906	MS35674-41
2	20	5340-00-116-1510	80063	SMB208663
2	21	5330-00-248-3847	96906	MS29513-115
2	22		81337	SC-C-200141
2	23		96906	MS171528
2	24		81337	SC-B-200143
2	25		81337	SC-B-200144
2	26		81337	SC-C-200142
2	27		81337	SC-B-200150
2	28		81337	SC-B-200151
2	29		96906	MS9466-13
2	30	5310-00-245-8826	96906	MS16228-10C
2	31		81337	SC-B-200146
2	32		81337	SC-B-200145
2	33		96906	MS35751-163
2	34	5365-00-173-7010	80063	SMB615259-1
2	35		81337	SC-B-595073
2	36	5320-00-956-7362	07707	AD62H
2	37		81337	SC-C-595537

CROSS-REFERENCE INDEXES

FIG.	ITEM	FIGURE AND ITEM NUMBER INDEX		PART NUMBER
		STOCK NUMBER	CAGEC	
2	38	5305-00-008-7868	80063	SMB208666
2	39		00770	30-401518
2	40	5340-01-065-8967	80063	SM-B-650093
2	41	5330-00-545-5221	81337	SM-C-564839
2	42		81337	SM-D-208680
3	1		81337	SM-D-208682
3	2	5305-00-702-9070	96906	MS35307-318
3	3	5310-00-245-8825	96906	MS16228-4C
3	4	5310-00-543-2740	96906	MS35333-74
3	5		81337	SM-C-563520
3	6		81337	SM-B-563523
3	7	5310-00-515-7449	88044	AN960C416L
3	8		81337	SM-C-563522
3	9	5310-00-595-6057	96906	MS15795-815
3	10	5340-01-091-7083	81337	SM-C-563521
3	11	5365-00-134-3251	80063	SMB359933
3	12		81337	SM-D-208682-5
3	13	5340-00-118-0018	81337	SM-B-450447
3	14	5305-00-958-5481	96906	MS35190-257
3	15	5410-01-140-0452	80063	SM-B-435927
3	16	5365-00-263-9561	80063	SMB435941
3	18	5305-00-052-6919	96906	MS24629-52
3	19	5310-00-045-3296	96906	MS35338-43
3	20		81337	SC-B-595543
3	21	5340-01-137-9055	80063	SM-B-435942
3	22		81337	SM-B-435943
3	23	5365-00-263-5969	80063	SMB435944
3	24	5305-00-054-6675	96906	MS51957-50
3	25		96906	MS35338-137
3	26		81337	SM-D-435907
3	27		81337	SM-B-564836
3	28	4130-00-143-9211	80063	SM-B-435924
3	29		03481	S8B201
3	30	5330-00-545-5221	81337	SM-C-564839
3	31	5305-00-984-7342	96906	MS35191-274
3	32	5310-00-934-9751	96906	MS35650-302
3	33		81337	SM-D-435912
3	34		73957	GP24-125X0625-50
3	35		81337	SM-D-435932
3	36		81337	SM-C-208692
3	37	5305-00-989-7435	96906	MS35207-264
3	38		81337	SM-C-435908-2
3	39		81337	SM-D-435931
3	40		81337	SM-C-650094
3	41		81337	SM-C-435928
3	42	5330-00-179-9225	80063	SMB435938
3	43	5315-01-049-1773	96906	MS171530
3	44	5310-00-279-9026	80063	SMB435902
3	45		81337	SM-B-435903-2
3	46		81337	SM-D-563202 GRVII

CROSS-REFERENCE INDEXES

FIG.	ITEM	FIGURE AND ITEM NUMBER INDEX		PART NUMBER
		STOCK NUMBER	CAGEC	
3	47		81337	SM-D-563202 GRV
3	48	5315-00-846-8337	96906	MS171659
3	49	5340-00-006-2358	80063	SMC208678-3
3	50	5315-00-062-5417	96906	MS35674-41
3	51	5340-00-116-1510	80063	SMB208663
3	52	5330-00-248-3847	96906	MS29513-115
3	53		81337	SC-C-200141
3	54		96906	MS171528
3	55		81337	SC-B-200143
3	56		81337	SC-B-200144
3	57		81337	SC-C-200142
3	58	5365-00-263-9576	80063	SMB208670
3	59		81337	SC-B-200150
3	60		81337	SC-B-200151
3	61	5315-00-008-9066	81337	SM-B-435903-1
3	62	5310-00-245-8826	96906	MS16228-10C
3	63		81337	SC-B-200146
3	64		81337	SC-B-200145
3	65	5306-00-268-2440	96906	MS35751-164
3	66		81337	SC-B-615259
3	67		81337	SC-B-595073
3	68		81337	SM-D-435911
3	69	5320-00-932-1972	07707	AD42H
3	70		81337	SM-C-564810
3	71		81337	SM-B-947239
3	72		81337	SM-C-435936
3	73		81337	SM-C-435937
3	73		81337	SM-C-650125
3	74		03481	S58B161
3	75		81337	SM-C-435935
3	96	5320-00-882-8386	07707	AD44H
3	77	5320-00-420-2169	07707	AK44H
3	78	5340-00-116-5796	80063	SMB450457
3	79	5305-00-988-1724	96906	MS35206-280
3	80	5310-00-245-8825	96906	MS16228-4C
3	81		81337	SM-D-435911-2
3	82		81337	SM-B-435910
3	83	5320-00-956-7355	07707	AD64H
3	84		81337	SM-B-208694
3	85		81337	SM-B-208693
3	86		81337	SM-C-564839
3	87	5670-00-182-8475	80063	SMC435913
3	88	5670-00-182-8476	80063	SMD208683
3	89		07700	21-43151
3	90		81337	SM-C-435909
4	1		81337	SM-D-435914
4	2		84256	53679-1
4	3	5365-01-102-9624	81982	53679
4	4	5315-00-008-9068	80063	SMB435919
4	5	5310-00-515-7449	88044	AN960C416L
4	6		81337	SM-B-781196

CROSS-REFERENCE INDEXES

FIGURE AND ITEM NUMBER INDEX				
FIG.	ITEM	STOCK NUMBER	CAGEC	PART NUMBER
4	7	5310-01-151-5131	80063	SM-B-435923
4	8		81337	SM-C-435920
4	9		81337	SM-C-435918
5	1		81337	SM-C-650082
5	2		81337	SM-C-563635
5	3		81337	SM-C-650046
5	4		07707	AK66H
5	5	5320-01-180-2566	80063	SM-C-563698-9
5	6		81337	SM-C-563539
5	7		81337	SM-B-563542
5	8		81337	SM-D-650047
5	9		81337	SM-D-563645
5	10	5320-00-070-2094	80205	NAS1399MW6-5
5	11		81337	SM-C-563646-1
5	12		81337	SM-C-563646-2
5	13		81337	SM-B-563648
5	14		81337	SM-C-563647
6	1		81337	SM-C-349315 GRI
6	2	5310-00-088-0552	96906	MS21044N7
6	3	5306-00-584-4911	88044	AN7C-22A
6	4	3940-00-933-4474	80063	SMB165462
6	5		81337	SM-D-349314
6	6		81337	SM-C-349315 GRII
6	7	5310-00-088-0552	96906	MS21044N7
6	8	5306-00-584-4911	88044	AN7C-22A
6	9	3940-00-933-4474	80063	SMB165462
6	10		81337	SM-D-349313
7	1		81337	SM-C-650075 GRI
7	2	5310-00-982-6809	96906	MS21044-N10
7	3		80063	SM-C-563721
7	4		81337	SC-B-865355
7	5		81337	SM-B-563516
7	6		81337	SM-D-650083-1
7	7		81337	SM-C-650075 GRII
7	8	5310-00-982-6809	96906	MS21044-N10
7	9		80063	SM-C-563721
7	10		81337	SC-B-865355
7	11		81337	SM-B-563516
7	12		81337	SM-D-650083-2

By Order of the Secretary of the Army:

CARL E. VUONO
General, United States Army
Chief of Staff

Official:

PATRICIA P. HICKERSON
Brigadier General, United States Army
The Adjutant General

DISTRIBUTION:

To be distributed in accordance with DA Form 12-25E, (qty rqr block no. 3646)

RECOMMENDED CHANGES TO EQUIPMENT TECHNICAL PUBLICATIONS



THEN... JOT DOWN THE DOPE ABOUT IT ON THIS FORM. CAREFULLY TEAR IT OUT. FOLD IT AND DROP IT IN THE MAIL!

SOMETHING WRONG WITH THIS PUBLICATION?

FROM: (PRINT YOUR UNIT'S COMPLETE ADDRESS)

PFC JOHN DOE
COA, 3d ENGINEER BN
FT. LEONARDWOOD, MA 63108

DATE SENT

PUBLICATION NUMBER

TM 10-5411-205-23P

PUBLICATION DATE

24 JUNE 1991

PUBLICATION TITLE

SHELTER, ELECTRICAL EQUIPMENT

BE EXACT. PIN-POINT WHERE IT IS

PAGE NO	PARA-GRAPH	FIGURE NO	TABLE NO
6	2-1 a		
B1		4-3	
125	line 20		

IN THIS SPACE TELL WHAT IS WRONG AND WHAT SHOULD BE DONE ABOUT IT:

In line 6 of paragraph 2-1a the manual states the engine has 6 cylinders. The engine on my set only has 4 cylinders. Change the manual to show 4 cylinders.

Callout 16 on figure 4-3 is pointing at a bolt. In key to figure 4-3, item 16 is called a shim - Please correct one or the other.

I ordered a gasket, item 19 on figure B-16 by NSN 2 910-00-762-3001. I got a gasket but it doesn't fit. Supply says I got what I ordered, so the NSN is wrong. Please give me a good NSN

PRINTED NAME, GRADE OR TITLE, AND TELEPHONE NUMBER

JOHN DOE, PFC (268) 317-7111

SIGN HERE

JOHN DOE

DA FORM 1 JUL 79 2028-2

PREVIOUS EDITIONS ARE OBSOLETE.
DRSTS-M Overprint 1, 1 Nov 80

P.S.--IF YOUR OUTFIT WANTS TO KNOW ABOUT YOUR RECOMMENDATION MAKE A CARBON COPY OF THIS AND GIVE IT TO YOUR HEADQUARTERS

TEAR ALONG PERFORATED LINE

RECOMMENDED CHANGES TO EQUIPMENT TECHNICAL PUBLICATIONS

SOMETHING WRONG WITH THIS PUBLICATION?



THEN... JOT DOWN THE DOPE ABOUT IT ON THIS FORM. CAREFULLY TEAR IT OUT. FOLD IT AND DROP IT IN THE MAIL!

FROM: (PRINT YOUR UNIT'S COMPLETE ADDRESS)

DATE SENT

PUBLICATION NUMBER

TM 10-5411-205-23P

PUBLICATION DATE

24 JUNE 1991

PUBLICATION TITLE

SHELTER, ELECTRICAL EQUIPMENT

BE EXACT PIN-POINT WHERE IT IS

PAGE NO	PARA-GRAPH	FIGURE NO	TABLE NO

IN THIS SPACE TELL WHAT IS WRONG AND WHAT SHOULD BE DONE ABOUT IT:

TEAR ALONG PERFORATED LINE

PRINTED NAME, GRADE OR TITLE AND TELEPHONE NUMBER

SIGN HERE

DA FORM 2028-2
1 JUL 79

PREVIOUS EDITIONS ARE OBSOLETE.
DRSTS-M Overprint 2, 1 Nov 80.

P.S.--IF YOUR OUTFIT WANTS TO KNOW ABOUT YOUR RECOMMENDATION MAKE A CARBON COPY OF THIS AND GIVE IT TO YOUR HEADQUARTERS.

FILL IN YOUR
UNIT'S ADDRESS



FOLD BACK

DEPARTMENT OF THE ARMY



OFFICIAL BUSINESS

COMMANDER
U.S. ARMY TROOP SUPPORT COMMAND
ATTN: AMSTR-MMTS
4300 GOODFELLOW BOULEVARD
ST. LOUIS, MO 63120-1798

TEAR ALONG PERFORATED LINE

The Metric System and Equivalents

Linear Measure

1 centimeter = 10 millimeters = .39 inch
 1 decimeter = 10 centimeters = 3.94 inches
 1 meter = 10 decimeters = 39.37 inches
 1 dekameter = 10 meters = 32.8 feet
 1 hectometer = 10 dekameters = 328.08 feet
 1 kilometer = 10 hectometers = 3,280.8 feet

Weights

1 centigram = 10 milligrams = .15 grain
 1 decigram = 10 centigrams = 1.54 grains
 1 gram = 10 decigram = .035 ounce
 1 dekagram = 10 grams = .35 ounce
 1 hectogram = 10 dekagrams = 3.52 ounces
 1 kilogram = 10 hectograms = 2.2 pounds
 1 quintal = 100 kilograms = 220.46 pounds
 1 metric ton = 10 quintals = 1.1 short tons

Liquid Measure

1 centiliter = 10 milliliters = .34 fl. ounce
 1 deciliter = 10 centiliters = 3.38 fl. ounces
 1 liter = 10 deciliters = 33.81 fl. ounces
 1 dekaliter = 10 liters = 2.64 gallons
 1 hectoliter = 10 dekaliters = 26.42 gallons
 1 kiloliter = 10 hectoliters = 264.18 gallons

Square Measure

1 sq. centimeter = 100 sq. millimeters = .155 sq. inch
 1 sq. decimeter = 100 sq. centimeters = 15.5 sq. inches
 1 sq. meter (centare) = 100 sq. decimeters = 10.76 sq. feet
 1 sq. dekameter (are) = 100 sq. meters = 1,076.4 sq. feet
 1 sq. hectometer (hectare) = 100 sq. dekameters = 2.47 acres
 1 sq. kilometer = 100 sq. hectometers = .386 sq. mile -

Cubic Measure

1 cu. centimeter = 1000 cu. millimeters = .06 cu. inch
 1 cu. decimeter = 1000 cu. centimeters = 61.02 cu. inches
 1 cu. meter = 1000 cu. decimeters = 35.31 cu. feet

Approximate Conversion Factors

To change	To	Multiply by	To change	To	Multiply by
inches	centimeters	2.540	ounce-inches	newton-meters	.007062
feet	meters	.305	centimeters	inches	.394
yards	meters	.914	meters	feet	3.280
miles	kilometers	1.609	meters	yards	1.094
square inches	square centimeters	6.451	kilometers	miles	.621
square feet	square meters	.093	square centimeters	square inches	.155
square yards	square meters	.836	square meters	square feet	10.764
square miles	square kilometers	2.590	square meters	square yards	1.196
acres	square hectometers	.405	square kilometers	square miles	.386
cubic feet	cubic meters	.028	square hectometers	acres	2.471
cubic yards	cubic meters	.765	square kilometers	cubic feet	35.315
fluid ounces	milliliters	29.573	cubic meters	cubic yards	1.308
pints	liters	.473	milliliters	fluid ounces	.034
quarts	liters	.946	liters	pints	2.113
gallons	liters	3.785	liters	quarts	1.057
ounces	grams	28.349	liters	gallons	.264
pounds	kilograms	.454	grams	ounces	.035
short tons	metric tons	.907	kilograms	pounds	2.205
pound-feet	newton-meters	1.356	metric tons	short tons	1.102
pound-inches	newton-meters	.11296			

Temperature (Exact)

°F	Fahrenheit temperature	5/9 (after subtracting 32)	Celsius temperature	°C
----	------------------------	----------------------------	---------------------	----

